

# Laboratory biosafety manual

Third edition



**World Health Organization**

Geneva

2004

WHO Library Cataloguing-in-Publication Data

World Health Organization.

Laboratory biosafety manual. – 3rd ed.

1.Containment of biohazards - methods 2.Laboratories - standards 3.Laboratory infection - prevention and control 4.Manuals I.Title.

ISBN 92 4 154650 6 (LC/NLM classification: QY 25) WHO/CDS/CSR/LYO/2004.11

*This publication was supported by Grant/Cooperative Agreement Number U50/CCU012445-08 from the Centers for Disease Control and Prevention (CDC), Atlanta, GA, USA. Its contents are solely the responsibility of the authors and do not necessarily represent the official views of the CDC.*

© World Health Organization 2004

All rights reserved. Publications of the World Health Organization can be obtained from Marketing and Dissemination, World Health Organization, 20 Avenue Appia, 1211 Geneva 27, Switzerland (tel: +41 22 791 2476; fax: +41 22 791 4857; email: bookorders@who.int). Requests for permission to reproduce or translate WHO publications – whether for sale or for noncommercial distribution – should be addressed to Publications, at the above address (fax: +41 22 791 4806; email: permissions@who.int).

The designations employed and the presentation of the material in this publication do not imply the expression of any opinion whatsoever on the part of the World Health Organization concerning the legal status of any country, territory, city or area or of its authorities, or concerning the delimitation of its frontiers or boundaries. Dotted lines on maps represent approximate border lines for which there may not yet be full agreement.

The mention of specific companies or of certain manufacturers' products does not imply that they are endorsed or recommended by the World Health Organization in preference to others of a similar nature that are not mentioned. Errors and omissions excepted, the names of proprietary products are distinguished by initial capital letters.

The World Health Organization does not warrant that the information contained in this publication is complete and correct and shall not be liable for any damages incurred as a result of its use.

Designed by minimum graphics

Printed in Malta

# Contents

Foreword	vii
Acknowledgements	viii
<b>1. General principles</b>	<b>1</b>
Introduction	1
<b>PART I. Biosafety guidelines</b>	<b>5</b>
<b>2. Microbiological risk assessment</b>	<b>7</b>
Specimens for which there is limited information	8
Risk assessment and genetically modified microorganisms	8
<b>3. Basic laboratories – Biosafety Levels 1 and 2</b>	<b>9</b>
Code of practice	9
Laboratory design and facilities	12
Laboratory equipment	14
Health and medical surveillance	16
Training	16
Waste handling	17
Chemical, fire, electrical, radiation and equipment safety	19
<b>4. The containment laboratory – Biosafety Level 3</b>	<b>20</b>
Code of practice	20
Laboratory design and facilities	21
Laboratory equipment	22
Health and medical surveillance	22
<b>5. The maximum containment laboratory – Biosafety Level 4</b>	<b>25</b>
Code of practice	25
Laboratory design and facilities	25
<b>6. Laboratory animal facilities</b>	<b>28</b>
Animal facility – Biosafety Level 1	29
Animal facility – Biosafety Level 2	29
Animal facility – Biosafety Level 3	30
Animal facility – Biosafety Level 4	31
Invertebrates	32
<b>7. Guidelines for laboratory/facility commissioning</b>	<b>33</b>
<b>8. Guidelines for laboratory/facility certification</b>	<b>36</b>

<b>PART II. Laboratory biosecurity</b>	<b>45</b>
<b>9. Laboratory biosecurity concepts</b>	47
<b>PART III. Laboratory equipment</b>	<b>49</b>
<b>10. Biological safety cabinets</b>	51
Class I biological safety cabinet	51
Class II biological safety cabinets	53
Class III biological safety cabinet	56
Biological safety cabinet air connections	56
Selection of a biological safety cabinet	57
Using biological safety cabinets in the laboratory	57
<b>11. Safety equipment</b>	61
Negative-pressure flexible-film isolators	61
Pipetting aids	63
Homogenizers, shakers, blenders and sonicators	63
Disposable transfer loops	64
Microincinerators	64
Personal protective equipment and clothing	64
<b>PART IV. Good microbiological techniques</b>	<b>67</b>
<b>12. Laboratory techniques</b>	69
Safe handling of specimens in the laboratory	69
Use of pipettes and pipetting aids	70
Avoiding the dispersal of infectious materials	70
Use of biological safety cabinets	70
Avoiding ingestion of infectious materials and contact with skin and eyes	71
Avoiding injection of infectious materials	71
Separation of serum	72
Use of centrifuges	72
Use of homogenizers, shakers, blenders and sonicators	73
Use of tissue grinders	73
Care and use of refrigerators and freezers	73
Opening of ampoules containing lyophilized infectious materials	74
Storage of ampoules containing infectious materials	74
Standard precautions with blood and other body fluids, tissues and excreta	74
Precautions with materials that may contain prions	76
<b>13. Contingency plans and emergency procedures</b>	78
Contingency plan	78
Emergency procedures for microbiological laboratories	79
<b>14. Disinfection and sterilization</b>	82
Definitions	82
Cleaning laboratory materials	83

## CONTENTS

Chemical germicides	83
Local environmental decontamination	88
Decontamination of biological safety cabinets	89
Hand-washing/hand decontamination	90
Heat disinfection and sterilization	90
Incineration	92
Disposal	93
<b>15. Introduction to the transport of infectious substances</b>	<b>94</b>
International transport regulations	94
The basic triple packaging system	95
Spill clean-up procedure	95
<b>PART V. Introduction to biotechnology</b>	<b>99</b>
<hr/>	
<b>16. Biosafety and recombinant DNA technology</b>	<b>101</b>
Biosafety considerations for biological expression systems	102
Biosafety considerations for expression vectors	102
Viral vectors for gene transfer	102
Transgenic and “knock-out” animals	102
Transgenic plants	103
Risk assessments for genetically modified organisms	103
Further considerations	104
<b>PART VI. Chemical, fire and electrical safety</b>	<b>105</b>
<hr/>	
<b>17. Hazardous chemicals</b>	<b>107</b>
Routes of exposure	107
Storage of chemicals	107
General rules regarding chemical incompatibilities	107
Toxic effects of chemicals	107
Explosive chemicals	108
Chemical spills	108
Compressed and liquefied gases	109
<b>18. Additional laboratory hazards</b>	<b>110</b>
Fire hazards	110
Electrical hazards	111
Noise	111
Ionizing radiation	111
<b>PART VII. Safety organization and training</b>	<b>115</b>
<hr/>	
<b>19. The biosafety officer and biosafety committee</b>	<b>117</b>
Biosafety officer	117
Biosafety committee	118

<b>20. Safety for support staff</b>	119
Engineering and building maintenance services	119
Cleaning (domestic) services	119
<b>21. Training programmes</b>	120
<b>PART VIII. Safety checklist</b>	<b>123</b>
<hr/>	
<b>22. Safety checklist</b>	125
Laboratory premises	125
Storage facilities	125
Sanitation and staff facilities	126
Heating and ventilation	126
Lighting	126
Services	126
Laboratory biosecurity	127
Fire prevention and fire protection	127
Flammable liquid storage	128
Compressed and liquefied gases	128
Electrical hazards	128
Personal protection	129
Health and safety of staff	129
Laboratory equipment	130
Infectious materials	130
Chemicals and radioactive substances	130
<b>PART IX. References, annexes and index</b>	<b>133</b>
<hr/>	
<b>References</b>	135
<b>Annex 1 First aid</b>	138
<b>Annex 2 Immunization of staff</b>	139
<b>Annex 3 WHO Biosafety Collaborating Centres</b>	140
<b>Annex 4 Equipment safety</b>	141
Equipment that may create a hazard	141
<b>Annex 5 Chemicals: hazards and precautions</b>	145
<b>Index</b>	170

# Foreword

The World Health Organization (WHO) has long recognized that safety and, in particular, biological safety are important international issues. WHO published the first edition of the *Laboratory biosafety manual* in 1983. The manual encouraged countries to accept and implement basic concepts in biological safety and to develop national codes of practice for the safe handling of pathogenic microorganisms in laboratories within their geographical borders. Since 1983, many countries have used the expert guidance provided in the manual to develop such codes of practice. A second edition of the manual was published in 1993.

WHO continues to provide international leadership in biosafety through this third edition of the manual by addressing biological safety and security issues facing us in the current millennium. The third edition stresses throughout the importance of personal responsibility. New chapters have been added on risk assessment, safe use of recombinant DNA technology and transport of infectious materials. Recent world events have revealed new threats to public health through deliberate misuse and release of microbiological agents and toxins. The third edition therefore also introduces biosecurity concepts – the protection of microbiological assets from theft, loss or diversion, which could lead to the inappropriate use of these agents to cause public health harm. This edition also includes safety information from the 1997 WHO publication *Safety in health-care laboratories* (1).

The third edition of the WHO *Laboratory biosafety manual* is a helpful reference and guide to nations that accept the challenge to develop and establish national codes of practice for securing microbiological assets, yet ensuring their availability for clinical, research and epidemiological purposes.



Dr A. Asamoah-Baah  
*Assistant Director-General  
Communicable Diseases  
World Health Organization  
Geneva, Switzerland*

# Acknowledgements

The development of this third edition of the *Laboratory biosafety manual* has been made possible through the contributions of the following, whose expertise is gratefully acknowledged:

- Dr W. Emmett Barkley, Howard Hughes Medical Institute, Chevy Chase, MD, USA  
Dr Murray L. Cohen, Centers for Disease Control and Prevention, Atlanta, GA, USA  
(retired)  
Dr Ingegerd Kallings, Swedish Institute of Infectious Disease Control, Stockholm, Sweden  
Ms Mary Ellen Kennedy, Consultant in Biosafety, Ashton, Ontario, Canada  
Ms Margery Kennett, Victorian Infectious Diseases Reference Laboratory, North Melbourne, Australia (retired)  
Dr Richard Knudsen, Office of Health and Safety, Centers for Disease Control and Prevention, Atlanta, GA, USA  
Dr Nicoletta Previsani, Biosafety programme, World Health Organization, Geneva, Switzerland  
Dr Jonathan Richmond, Office of Health and Safety, Centers for Disease Control and Prevention, Atlanta, GA, USA (retired)  
Dr Syed A. Sattar, Faculty of Medicine, University of Ottawa, Ottawa, Ontario, Canada  
Dr Deborah E. Wilson, Division of Occupational Health and Safety, Office of Research Services, National Institutes of Health, Department of Health and Human Services, Washington, DC, USA  
Dr Riccardo Wittek, Institute of Animal Biology, University of Lausanne, Lausanne, Switzerland

The assistance of the following is also gratefully acknowledged:

- Ms Maureen Best, Office of Laboratory Security, Health Canada, Ottawa, Canada  
Dr Mike Catton, Victorian Infectious Diseases Reference Laboratory, North Melbourne, Australia  
Dr Shanna Nesby, Office of Health and Safety, Centers for Disease Control and Prevention, Atlanta, GA, USA  
Dr Stefan Wagener, Canadian Science Centre for Human and Animal Health, Winnipeg, Canada

The writers and reviewers also wish to acknowledge the original contributions of the many professionals whose work was embodied in the first and second editions of the *Laboratory biosafety manual* and in the 1997 WHO publication *Safety in health-care laboratories* (1).



# 1. General principles

## Introduction

Throughout this manual, references are made to the relative hazards of infective microorganisms by risk group (WHO Risk Groups 1, 2, 3 and 4). **This risk group classification is to be used for laboratory work only.** Table 1 describes the risk groups.

*Table 1. Classification of infective microorganisms by risk group*

---

**Risk Group 1** (*no or low individual and community risk*)

A microorganism that is unlikely to cause human or animal disease.

**Risk Group 2** (*moderate individual risk, low community risk*)

A pathogen that can cause human or animal disease but is unlikely to be a serious hazard to laboratory workers, the community, livestock or the environment. Laboratory exposures may cause serious infection, but effective treatment and preventive measures are available and the risk of spread of infection is limited.

**Risk Group 3** (*high individual risk, low community risk*)

A pathogen that usually causes serious human or animal disease but does not ordinarily spread from one infected individual to another. Effective treatment and preventive measures are available.

**Risk Group 4** (*high individual and community risk*)

A pathogen that usually causes serious human or animal disease and that can be readily transmitted from one individual to another, directly or indirectly. Effective treatment and preventive measures are not usually available.

---

Laboratory facilities are designated as basic – Biosafety Level 1, basic – Biosafety Level 2, containment – Biosafety Level 3, and maximum containment – Biosafety Level 4. Biosafety level designations are based on a composite of the design features, construction, containment facilities, equipment, practices and operational procedures required for working with agents from the various risk groups. Table 2 relates but **does not “equate”** risk groups to the biosafety level of laboratories designed to work with organisms in each risk group.

Countries (regions) should draw up a national (regional) classification of microorganisms, by risk group, taking into account:

**Table 2. Relation of risk groups to biosafety levels, practices and equipment**

RISK GROUP	BIO SAFETY LEVEL	LABORATORY TYPE	LABORATORY PRACTICES	SAFETY EQUIPMENT
1	Basic – Biosafety Level 1	Basic teaching, research	GMT	None; open bench work
2	Basic – Biosafety Level 2	Primary health services; diagnostic services, research	GMT plus protective clothing, biohazard sign	Open bench plus BSC for potential aerosols
3	Containment – Biosafety Level 3	Special diagnostic services, research	As Level 2 plus special clothing, controlled access, directional airflow	BSC and/or other primary devices for all activities
4	Maximum containment – Biosafety Level 4	Dangerous pathogen units	As Level 3 plus airlock entry, shower exit, special waste disposal	Class III BSC, or positive pressure suits in conjunction with Class II BSCs, double-ended autoclave (through the wall), filtered air

BSC, biological safety cabinet; GMT, good microbiological techniques (see Part IV of this manual)

1. Pathogenicity of the organism.
2. Mode of transmission and host range of the organism. These may be influenced by existing levels of immunity in the local population, density and movement of the host population, presence of appropriate vectors, and standards of environmental hygiene.
3. Local availability of effective preventive measures. These may include: prophylaxis by immunization or administration of antisera (passive immunization); sanitary measures, e.g. food and water hygiene; control of animal reservoirs or arthropod vectors.
4. Local availability of effective treatment. This includes passive immunization, postexposure vaccination and use of antimicrobials, antivirals and chemotherapeutic agents, and should take into consideration the possibility of the emergence of drug-resistant strains.

The assignment of an agent to a biosafety level for laboratory work must be based on a risk assessment. Such an assessment will take the risk group as well as other factors into consideration in establishing the appropriate biosafety level. For example, an agent that is assigned to Risk Group 2 may generally require Biosafety Level 2 facilities, equipment, practices and procedures for safe conduct of work. However, if particular experiments require the generation of high-concentration aerosols, then Biosafety

## 1. GENERAL PRINCIPLES

Level 3 may be more appropriate to provide the necessary degree of safety, since it ensures superior containment of aerosols in the laboratory workplace. The biosafety level assigned for the specific work to be done is therefore driven by professional judgement based on a risk assessment, rather than by automatic assignment of a laboratory biosafety level according to the particular risk group designation of the pathogenic agent to be used (see Chapter 2).

Table 3 summarizes the facility requirements at the four biosafety levels.

**Table 3. Summary of biosafety level requirements**

	BIOSAFETY LEVEL			
	1	2	3	4
Isolation <sup>a</sup> of laboratory	No	No	Yes	Yes
Room sealable for decontamination	No	No	Yes	Yes
Ventilation:				
— inward airflow	No	Desirable	Yes	Yes
— controlled ventilating system	No	Desirable	Yes	Yes
— HEPA-filtered air exhaust	No	No	Yes/No <sup>b</sup>	Yes
Double-door entry	No	No	Yes	Yes
Airlock	No	No	No	Yes
Airlock with shower	No	No	No	Yes
Anteroom	No	No	Yes	—
Anteroom with shower	No	No	Yes/No <sup>c</sup>	No
Effluent treatment	No	No	Yes/No <sup>c</sup>	Yes
Autoclave:				
— on site	No	Desirable	Yes	Yes
— in laboratory room	No	No	Desirable	Yes
— double-ended	No	No	Desirable	Yes
Biological safety cabinets	No	Desirable	Yes	Yes
Personnel safety monitoring capability <sup>d</sup>	No	No	Desirable	Yes

<sup>a</sup> Environmental and functional isolation from general traffic.

<sup>b</sup> Dependent on location of exhaust (see Chapter 4).

<sup>c</sup> Dependent on agent(s) used in the laboratory.

<sup>d</sup> For example, window, closed-circuit television, two-way communication.

Thus, the assignment of a biosafety level takes into consideration the organism (pathogenic agent) used, the facilities available, and the equipment practices and procedures required to conduct work safely in the laboratory.





**PART I**

# Biosafety guidelines



## 2. Microbiological risk assessment

The backbone of the practice of biosafety is risk assessment. While there are many tools available to assist in the assessment of risk for a given procedure or experiment, the most important component is professional judgement. Risk assessments should be performed by the individuals most familiar with the specific characteristics of the organisms being considered for use, the equipment and procedures to be employed, animal models that may be used, and the containment equipment and facilities available. The laboratory director or principal investigator is responsible for ensuring that adequate and timely risk assessments are performed, and for working closely with the institution's safety committee and biosafety personnel to ensure that appropriate equipment and facilities are available to support the work being considered. Once performed, risk assessments should be reviewed routinely and revised when necessary, taking into consideration the acquisition of new data having a bearing on the degree of risk and other relevant new information from the scientific literature.

One of the most helpful tools available for performing a microbiological risk assessment is the listing of risk groups for microbiological agents (see Chapter 1). However, simple reference to the risk grouping for a particular agent is insufficient in the conduct of a risk assessment. Other factors that should be considered, as appropriate, include:

1. Pathogenicity of the agent and infectious dose
2. Potential outcome of exposure
3. Natural route of infection
4. Other routes of infection, resulting from laboratory manipulations (parenteral, airborne, ingestion)
5. Stability of the agent in the environment
6. Concentration of the agent and volume of concentrated material to be manipulated
7. Presence of a suitable host (human or animal)
8. Information available from animal studies and reports of laboratory-acquired infections or clinical reports
9. Laboratory activity planned (sonication, aerosolization, centrifugation, etc.)
10. Any genetic manipulation of the organism that may extend the host range of the agent or alter the agent's sensitivity to known, effective treatment regimens (see Chapter 16)
11. Local availability of effective prophylaxis or therapeutic interventions.

On the basis of the information ascertained during the risk assessment, a biosafety level can be assigned to the planned work, appropriate personal protective equipment selected, and standard operating procedures (SOPs) incorporating other safety interventions developed to ensure the safest possible conduct of the work.

### **Specimens for which there is limited information**

The risk assessment procedure described above works well when there is adequate information available. However, there are situations when the information is insufficient to perform an appropriate risk assessment, for example, with clinical specimens or epidemiological samples collected in the field. In these cases, it is prudent to take a cautious approach to specimen manipulation.

1. Standard precautions (2) should always be followed, and barrier protections applied (gloves, gowns, eye protection), whenever samples are obtained from patients.
2. Basic containment – Biosafety Level 2 practices and procedures should be the minimum requirement for handling specimens.
3. Transport of specimens should follow national and/or international rules and regulations.

Some information may be available to assist in determining the risk of handling these specimens:

1. Medical data on the patient
2. Epidemiological data (morbidity and mortality data, suspected route of transmission, other outbreak investigation data)
3. Information on the geographical origin of the specimen.

In the case of outbreaks of disease of unknown etiology, appropriate ad hoc guidelines may be generated and posted by national competent authorities and/or WHO on the World Wide Web (as was the case during the 2003 emergence of the severe acute respiratory syndrome (SARS)) to indicate how specimens should be consigned for shipment and the biosafety level at which they should be analysed.

### **Risk assessment and genetically modified microorganisms**

A detailed discussion of risk assessment and genetically modified organisms (GMOs) is provided in Chapter 16.



# 3. Basic laboratories – Biosafety Levels 1 and 2

For the purposes of this manual, the guidance and recommendations given as minimum requirements pertaining to laboratories of all biosafety levels are directed at microorganisms in Risk Groups 1–4. Although some of the precautions may appear to be unnecessary for some organisms in Risk Group 1, they are desirable for training purposes to promote good (i.e. safe) microbiological techniques (GMT).

Diagnostic and health-care laboratories (public health, clinical or hospital-based) must all be designed for Biosafety Level 2 or above. As no laboratory has complete control over the specimens it receives, laboratory workers may be exposed to organisms in higher risk groups than anticipated. This possibility must be recognized in the development of safety plans and policies. In some countries, accreditation of clinical laboratories is required. Globally, standard precautions (2) should always be adopted and practised.

The guidelines for basic laboratories – Biosafety Levels 1 and 2 presented here are comprehensive and detailed, as they are fundamental to laboratories of all biosafety levels. The guidelines for containment laboratories – Biosafety Level 3 and maximum containment laboratories – Biosafety Level 4 that follow (Chapters 4 and 5) are modifications of and additions to these guidelines, designed for work with the more dangerous (hazardous) pathogens.

## **Code of practice**

This code is a listing of the most essential laboratory practices and procedures that are basic to GMT. In many laboratories and national laboratory programmes, this code may be used to develop written practices and procedures for safe laboratory operations.

Each laboratory should adopt a safety or operations manual that identifies known and potential hazards, and specifies practices and procedures to eliminate or minimize such hazards. GMT are fundamental to laboratory safety. Specialized laboratory equipment is a supplement to but can never replace appropriate procedures. The most important concepts are listed below.

## **Access**

1. The international biohazard warning symbol and sign (Figure 1) must be displayed on the doors of the rooms where microorganisms of Risk Group 2 or higher risk groups are handled.

Figure 1. *Biohazard warning sign for laboratory doors*



2. Only authorized persons should be allowed to enter the laboratory working areas.
3. Laboratory doors should be kept closed.
4. Children should not be authorized or allowed to enter laboratory working areas.
5. Access to animal houses should be specially authorized.
6. No animals should be admitted other than those involved in the work of the laboratory.

### ***Personal protection***

1. Laboratory coveralls, gowns or uniforms must be worn at all times for work in the laboratory.
2. Appropriate gloves must be worn for all procedures that may involve direct or accidental contact with blood, body fluids and other potentially infectious materials or infected animals. After use, gloves should be removed aseptically and hands must then be washed.
3. Personnel must wash their hands after handling infectious materials and animals, and before they leave the laboratory working areas.

4. Safety glasses, face shields (visors) or other protective devices must be worn when it is necessary to protect the eyes and face from splashes, impacting objects and sources of artificial ultraviolet radiation.
5. It is prohibited to wear protective laboratory clothing outside the laboratory, e.g. in canteens, coffee rooms, offices, libraries, staff rooms and toilets.
6. Open-toed footwear must not be worn in laboratories.
7. Eating, drinking, smoking, applying cosmetics and handling contact lenses is prohibited in the laboratory working areas.
8. Storing human foods or drinks anywhere in the laboratory working areas is prohibited.
9. Protective laboratory clothing that has been used in the laboratory must not be stored in the same lockers or cupboards as street clothing.

### ***Procedures***

1. Pipetting by mouth must be strictly forbidden.
2. Materials must not be placed in the mouth. Labels must not be licked.
3. All technical procedures should be performed in a way that minimizes the formation of aerosols and droplets.
4. The use of hypodermic needles and syringes should be limited. They must not be used as substitutes for pipetting devices or for any purpose other than parenteral injection or aspiration of fluids from laboratory animals.
5. All spills, accidents and overt or potential exposures to infectious materials must be reported to the laboratory supervisor. A written record of such accidents and incidents should be maintained.
6. A written procedure for the clean-up of all spills must be developed and followed.
7. Contaminated liquids must be decontaminated (chemically or physically) before discharge to the sanitary sewer. An effluent treatment system may be required, depending on the risk assessment for the agent(s) being handled.
8. Written documents that are expected to be removed from the laboratory need to be protected from contamination while in the laboratory.

### ***Laboratory working areas***

1. The laboratory should be kept neat, clean and free of materials that are not pertinent to the work.
2. Work surfaces must be decontaminated after any spill of potentially dangerous material and at the end of the working day.
3. All contaminated materials, specimens and cultures must be decontaminated before disposal or cleaning for reuse.
4. Packing and transportation must follow applicable national and/or international regulations.
5. When windows can be opened, they should be fitted with arthropod-proof screens.

### ***Biosafety management***

1. It is the responsibility of the laboratory director (the person who has immediate responsibility for the laboratory) to ensure the development and adoption of a biosafety management plan and a safety or operations manual.
2. The laboratory supervisor (reporting to the laboratory director) should ensure that regular training in laboratory safety is provided.
3. Personnel should be advised of special hazards, and required to read the safety or operations manual and follow standard practices and procedures. The laboratory supervisor should make sure that all personnel understand these. A copy of the safety or operations manual should be available in the laboratory.
4. There should be an arthropod and rodent control programme.
5. Appropriate medical evaluation, surveillance and treatment should be provided for all personnel in case of need, and adequate medical records should be maintained.

### ***Laboratory design and facilities***

In designing a laboratory and assigning certain types of work to it, special attention should be paid to conditions that are known to pose safety problems. These include:

1. Formation of aerosols
2. Work with large volumes and/or high concentrations of microorganisms
3. Overcrowding and too much equipment
4. Infestation with rodents and arthropods
5. Unauthorized entrance
6. Workflow: use of specific samples and reagents.

Examples of laboratory designs for Biosafety Levels 1 and 2 are shown in Figures 2 and 3, respectively.

### ***Design features***

1. Ample space must be provided for the safe conduct of laboratory work and for cleaning and maintenance.
2. Walls, ceilings and floors should be smooth, easy to clean, impermeable to liquids and resistant to the chemicals and disinfectants normally used in the laboratory. Floors should be slip-resistant.
3. Bench tops should be impervious to water and resistant to disinfectants, acids, alkalis, organic solvents and moderate heat.
4. Illumination should be adequate for all activities. Undesirable reflections and glare should be avoided.
5. Laboratory furniture should be sturdy. Open spaces between and under benches, cabinets and equipment should be accessible for cleaning.
6. Storage space must be adequate to hold supplies for immediate use and thus prevent clutter on bench tops and in aisles. Additional long-term storage space, conveniently located outside the laboratory working areas, should also be provided.

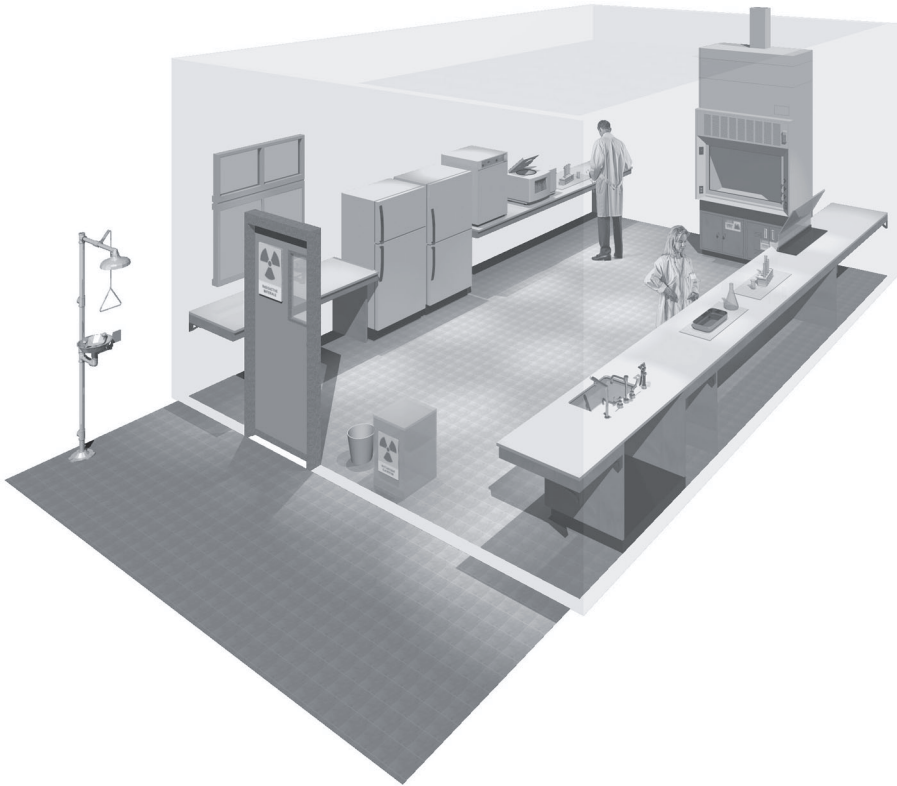

*Figure 2. A typical Biosafety Level 1 laboratory  
(graphics kindly provided by CUH2A, Princeton, NJ, USA)*

7. Space and facilities should be provided for the safe handling and storage of solvents, radioactive materials, and compressed and liquefied gases.
8. Facilities for storing outer garments and personal items should be provided outside the laboratory working areas.
9. Facilities for eating and drinking and for rest should be provided outside the laboratory working areas.
10. Hand-washing basins, with running water if possible, should be provided in each laboratory room, preferably near the exit door.
11. Doors should have vision panels, appropriate fire ratings, and preferably be self-closing.
12. At Biosafety Level 2, an autoclave or other means of decontamination should be available in appropriate proximity to the laboratory.
13. Safety systems should cover fire, electrical emergencies, emergency shower and eyewash facilities.
14. First-aid areas or rooms suitably equipped and readily accessible should be available (see Annex 1).

15. In the planning of new facilities, consideration should be given to the provision of mechanical ventilation systems that provide an inward flow of air without recirculation. If there is no mechanical ventilation, windows should be able to be opened and should be fitted with arthropod-proof screens.
16. A dependable supply of good quality water is essential. There should be no cross-connections between sources of laboratory and drinking-water supplies. An anti-backflow device should be fitted to protect the public water system.
17. There should be a reliable and adequate electricity supply and emergency lighting to permit safe exit. A stand-by generator is desirable for the support of essential equipment, such as incubators, biological safety cabinets, freezers, etc., and for the ventilation of animal cages.
18. There should be a reliable and adequate supply of gas. Good maintenance of the installation is mandatory.
19. Laboratories and animal houses are occasionally the targets of vandals. Physical and fire security must be considered. Strong doors, screened windows and restricted issue of keys are compulsory. Other measures should be considered and applied, as appropriate, to augment security (see Chapter 9).

### **Laboratory equipment**

Together with good procedures and practices, the use of safety equipment will help to reduce risks when dealing with biosafety hazards. This section deals with basic principles related to equipment suitable for laboratories of all biosafety levels. Requirements for laboratory equipment pertinent to higher biosafety levels are dealt with in the relevant chapters.

The laboratory director should, after consultation with the biosafety officer and safety committee (if designated), ensure that adequate equipment is provided and that it is used properly. Equipment should be selected to take account of certain general principles, i.e. it should be:

1. Designed to prevent or limit contact between the operator and the infectious material
2. Constructed of materials that are impermeable to liquids, resistant to corrosion and meet structural requirements
3. Fabricated to be free of burrs, sharp edges and unguarded moving parts
4. Designed, constructed and installed to facilitate simple operation and provide for ease of maintenance, cleaning, decontamination and certification testing; glassware and other breakable materials should be avoided, whenever possible.

Detailed performance and construction specifications may need to be consulted to ensure that the equipment possesses the necessary safety features (see also Chapters 10 and 11).

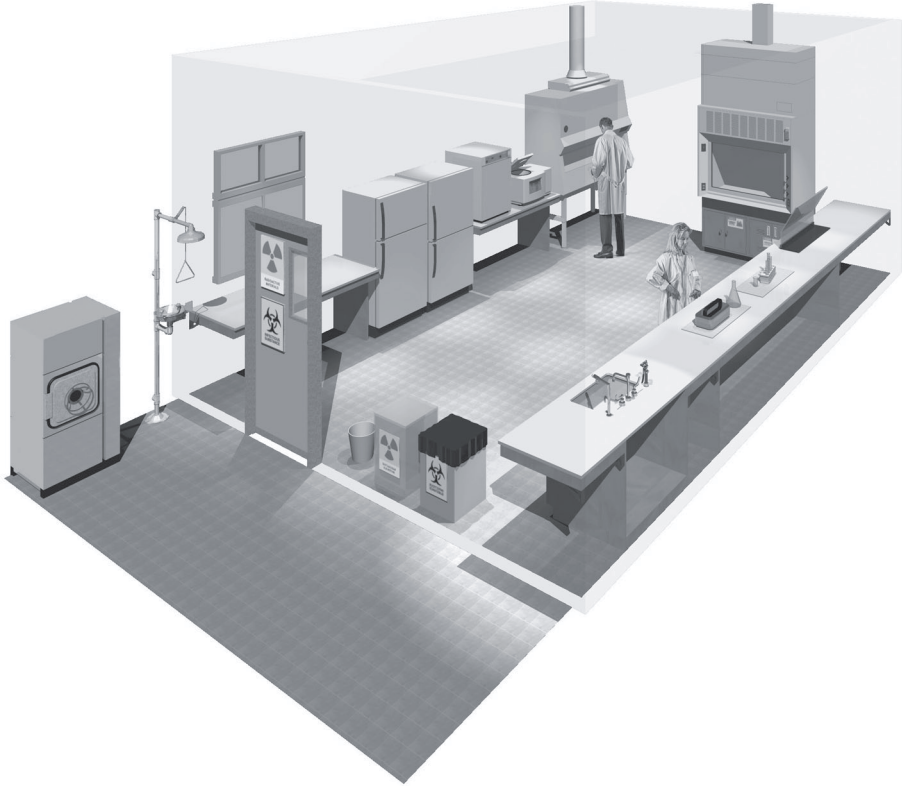

**Figure 3. A typical Biosafety Level 2 laboratory** (graphics kindly provided by CUH2A, Princeton, NJ, USA). Procedures likely to generate aerosols are performed within a biological safety cabinet. Doors are kept closed and are posted with appropriate hazard signs. Potentially contaminated wastes are separated from the general waste stream.

### **Essential biosafety equipment**

1. Pipetting aids – to avoid mouth pipetting. Many different designs are available.
2. Biological safety cabinets, to be used whenever:
  - infectious materials are handled; such materials may be centrifuged in the open laboratory if sealed centrifuge safety cups are used and if they are loaded and unloaded in a biological safety cabinet
  - there is an increased risk of airborne infection
  - procedures with a high potential for producing aerosols are used; these may include centrifugation, grinding, blending, vigorous shaking or mixing, sonic disruption, opening of containers of infectious materials whose internal pressure may be different from the ambient pressure, intranasal inoculation of animals, and harvesting of infectious tissues from animals and eggs.
3. Plastic disposable transfer loops. Alternatively, electric transfer loop incinerators may be used inside the biological safety cabinet to reduce aerosol production.

4. Screw-capped tubes and bottles.
5. Autoclaves or other appropriate means to decontaminate infectious materials.
6. Plastic disposable Pasteur pipettes, whenever available, to avoid glass.
7. Equipment such as autoclaves and biological safety cabinets must be validated with appropriate methods before being taken into use. Recertification should take place at regular intervals, according to the manufacturer's instructions (see Chapter 7).

### **Health and medical surveillance**

The employing authority, through the laboratory director, is responsible for ensuring that there is adequate surveillance of the health of laboratory personnel. The objective of such surveillance is to monitor for occupationally acquired diseases. Appropriate activities to achieve these objectives are:

1. Provision of active or passive immunization where indicated (see Annex 2)
2. Facilitation of the early detection of laboratory-acquired infections
3. Exclusion of highly susceptible individuals (e.g. pregnant women or immunocompromised individuals) from highly hazardous laboratory work
4. Provision of effective personal protective equipment and procedures.

### ***Guidelines for the surveillance of laboratory workers handling microorganisms at Biosafety Level 1***

Historical evidence indicates that the microorganisms handled at this level are unlikely to cause human disease or animal disease of veterinary importance. Ideally, however, all laboratory workers should undergo a pre-employment health check at which their medical history is recorded. Prompt reporting of illnesses or laboratory accidents is desirable and all staff members should be made aware of the importance of maintaining GMT.

### ***Guidelines for the surveillance of laboratory workers handling microorganisms at Biosafety Level 2***

1. A pre-employment or preplacement health check is necessary. The person's medical history should be recorded and a targeted occupational health assessment performed.
2. Records of illness and absence should be kept by the laboratory management.
3. Women of childbearing age should be made aware of the risk to an unborn child of occupational exposure to certain microorganisms, e.g. rubella virus. The precise steps taken to protect the fetus will vary, depending on the microorganisms to which the women may be exposed.

### **Training**

Human error and poor technique can compromise the best of safeguards to protect the laboratory worker. Thus, a safety-conscious staff, well informed about the recognition and control of laboratory hazards, is key to the prevention of laboratory-



acquired infections, incidents and accidents. For this reason, continuous in-service training in safety measures is essential. An effective safety programme begins with the laboratory managers, who should ensure that safe laboratory practices and procedures are integrated into the basic training of employees. Training in safety measures should be an integral part of new employees' introduction to the laboratory. Employees should be introduced to the code of practice and to local guidelines, including the safety or operations manual. Measures to assure that employees have read and understood the guidelines, such as signature pages, should be adopted. Laboratory supervisors play the key role in training their immediate staff in good laboratory techniques. The biosafety officer can assist in training and with the development of training aids and documentation (see also Chapter 21).

Staff training should always include information on safe methods for highly hazardous procedures that are commonly encountered by all laboratory personnel and which involve:

1. Inhalation risks (i.e. aerosol production) when using loops, streaking agar plates, pipetting, making smears, opening cultures, taking blood/serum samples, centrifuging, etc.
2. Ingestion risks when handling specimens, smears and cultures
3. Risks of percutaneous exposures when using syringes and needles
4. Bites and scratches when handling animals
5. Handling of blood and other potentially hazardous pathological materials
6. Decontamination and disposal of infectious material.

### **Waste handling**

Waste is anything that is to be discarded.

In laboratories, decontamination of wastes and their ultimate disposal are closely interrelated. In terms of daily use, few if any contaminated materials will require actual removal from the laboratory or destruction. Most glassware, instruments and laboratory clothing will be reused or recycled. The overriding principle is that all infectious materials should be decontaminated, autoclaved or incinerated within the laboratory.

The principal questions to be asked before discharge of any objects or materials from laboratories that deal with potentially infectious microorganisms or animal tissues are:

1. Have the objects or materials been effectively decontaminated or disinfected by an approved procedure?
2. If not, have they been packaged in an approved manner for immediate on-site incineration or transfer to another facility with incineration capacity?
3. Does the disposal of the decontaminated objects or materials involve any additional potential hazards, biological or otherwise, to those who carry out the immediate disposal procedures or who might come into contact with discarded items outside the facility?

***Decontamination***

Steam autoclaving is the preferred method for all decontamination processes. Materials for decontamination and disposal should be placed in containers, e.g. autoclavable plastic bags, that are colour-coded according to whether the contents are to be autoclaved and/or incinerated. Alternative methods may be envisaged only if they remove and/or kill microorganisms (for more details see Chapter 14).

***Handling and disposal procedures for contaminated materials and wastes***

An identification and separation system for infectious materials and their containers should be adopted. National and international regulations must be followed. Categories should include:

1. Non-contaminated (non-infectious) waste that can be reused or recycled or disposed of as general, “household” waste
2. Contaminated (infectious) “sharps” – hypodermic needles, scalpels, knives and broken glass; these should always be collected in puncture-proof containers fitted with covers and treated as infectious
3. Contaminated material for decontamination by autoclaving and thereafter washing and reuse or recycling
4. Contaminated material for autoclaving and disposal
5. Contaminated material for direct incineration.

***Sharps***

After use, hypodermic needles should not be recapped, clipped or removed from disposable syringes. The complete assembly should be placed in a sharps disposal container. Disposable syringes, used alone or with needles, should be placed in sharps disposal containers and incinerated, with prior autoclaving if required.

Sharps disposal containers must be puncture-proof/-resistant and must not be filled to capacity. When they are three-quarters full they should be placed in “infectious waste” containers and incinerated, with prior autoclaving if laboratory practice requires it. Sharps disposal containers must not be discarded in landfills.

***Contaminated (potentially infectious) materials for autoclaving and reuse***

No precleaning should be attempted of any contaminated (potentially infectious) materials to be autoclaved and reused. Any necessary cleaning or repair must be done only after autoclaving or disinfection.

***Contaminated (potentially infectious) materials for disposal***

Apart from sharps, which are dealt with above, all contaminated (potentially infectious) materials should be autoclaved in leakproof containers, e.g. autoclavable, colour-coded plastic bags, before disposal. After autoclaving, the material may be placed in transfer containers for transport to the incinerator. If possible, materials deriving from health-care activities should not be discarded in landfills even after decontamination. If an

incinerator is available on the laboratory site, autoclaving may be omitted: the contaminated waste should be placed in designated containers (e.g. colour-coded bags) and transported directly to the incinerator. Reusable transfer containers should be leakproof and have tight-fitting covers. They should be disinfected and cleaned before they are returned to the laboratory for further use.

Discard containers, pans or jars, preferably unbreakable (e.g. plastic), should be placed at every work station. When disinfectants are used, waste materials should remain in intimate contact with the disinfectant (i.e. not protected by air bubbles) for the appropriate time, according to the disinfectant used (see Chapter 14). The discard containers should be decontaminated and washed before reuse.

Incineration of contaminated waste must meet with the approval of the public health and air pollution authorities, as well as that of the laboratory biosafety officer (see section on Incineration in Chapter 14).

### **Chemical, fire, electrical, radiation and equipment safety**

A breakdown in the containment of pathogenic organisms may be the indirect result of chemical, fire, electrical or radiation accidents. It is therefore essential to maintain high standards of safety in these fields in any microbiological laboratory. Statutory rules and regulations for each of these will normally be laid down by the competent national or local authority, whose assistance should be sought if necessary. Chemical, fire, electrical and radiation hazards are considered in greater detail in Part VI of this manual (Chapters 17 and 18).

Additional information regarding safety equipment is presented in Chapter 11.

## 4. The containment laboratory – Biosafety Level 3

The containment laboratory – Biosafety Level 3 is designed and provided for work with Risk Group 3 microorganisms and with large volumes or high concentrations of Risk Group 2 microorganisms that pose an increased risk of aerosol spread. Biosafety Level 3 containment requires the strengthening of the operational and safety programmes over and above those for basic laboratories – Biosafety Levels 1 and 2 (set out in Chapter 3).

The guidelines given in this chapter are presented in the form of additions to those for basic laboratories – Biosafety Levels 1 and 2, which must therefore be applied before those specific for the containment laboratory – Biosafety Level 3. The major additions and changes are in:

1. Code of practice
2. Laboratory design and facilities
3. Health and medical surveillance.

Laboratories in this category should be registered or listed with the national or other appropriate health authorities.

### Code of practice

The code of practice for basic laboratories – Biosafety Levels 1 and 2 applies except where modified as follows.

1. The international biohazard warning symbol and sign (see Figure 1) displayed on laboratory access doors must identify the biosafety level and the name of the laboratory supervisor who controls access, and indicate any special conditions for entry into the area, e.g. immunization.
2. Laboratory protective clothing must be of the type with solid-front or wrap-around gowns, scrub suits, coveralls, head covering and, where appropriate, shoe covers or dedicated shoes. Front-buttoned standard laboratory coats are unsuitable, as are sleeves that do not fully cover the forearms. Laboratory protective clothing must not be worn outside the laboratory, and it must be decontaminated before it is laundered. The removal of street clothing and change into dedicated laboratory clothing may be warranted when working with certain agents (e.g. agricultural or zoonotic agents).

3. Open manipulations of all potentially infectious material must be conducted within a biological safety cabinet or other primary containment device (see also Chapter 10).
4. Respiratory protective equipment may be necessary for some laboratory procedures or working with animals infected with certain pathogens (see Chapter 11).

### **Laboratory design and facilities**

The laboratory design and facilities for basic laboratories – Biosafety Levels 1 and 2 apply except where modified as follows:

1. The laboratory must be separated from the areas that are open to unrestricted traffic flow within the building. Additional separation may be achieved by placing the laboratory at the blind end of a corridor, or constructing a partition and door or access through an anteroom (e.g. a double-door entry or basic laboratory – Biosafety Level 2), describing a specific area designed to maintain the pressure differential between the laboratory and its adjacent space. The anteroom should have facilities for separating clean and dirty clothing and a shower may also be necessary.
2. Anteroom doors may be self-closing and interlocking so that only one door is open at a time. A break-through panel may be provided for emergency exit use.
3. Surfaces of walls, floors and ceilings should be water-resistant and easy to clean. Openings through these surfaces (e.g. for service pipes) should be sealed to facilitate decontamination of the room(s).
4. The laboratory room must be sealable for decontamination. Air-ducting systems must be constructed to permit gaseous decontamination.
5. Windows must be closed, sealed and break-resistant.
6. A hand-washing station with hands-free controls should be provided near each exit door.
7. There must be a controlled ventilation system that maintains a directional airflow into the laboratory room. A visual monitoring device with or without alarm(s) should be installed so that staff can at all times ensure that proper directional airflow into the laboratory room is maintained.
8. The building ventilation system must be so constructed that air from the containment laboratory – Biosafety Level 3 is not recirculated to other areas within the building. Air may be high-efficiency particulate air (HEPA) filtered, reconditioned and recirculated within that laboratory. When exhaust air from the laboratory (other than from biological safety cabinets) is discharged to the outside of the building, it must be dispersed away from occupied buildings and air intakes. Depending on the agents in use, this air may be discharged through HEPA filters. A heating, ventilation and air-conditioning (HVAC) control system may be installed to prevent sustained positive pressurization of the laboratory. Consideration should be given to the installation of audible or clearly visible alarms to notify personnel of HVAC system failure.

9. All HEPA filters must be installed in a manner that permits gaseous decontamination and testing.
10. Biological safety cabinets should be sited away from walking areas and out of cross-currents from doors and ventilation systems (see Chapter 10).
11. The exhaust air from Class I or Class II biological safety cabinets (see Chapter 10), which will have been passed through HEPA filters, must be discharged in such a way as to avoid interference with the air balance of the cabinet or the building exhaust system.
12. An autoclave for the decontamination of contaminated waste material should be available in the containment laboratory. If infectious waste has to be removed from the containment laboratory for decontamination and disposal, it must be transported in sealed, unbreakable and leakproof containers according to national or international regulations, as appropriate.
13. Backflow-precaution devices must be fitted to the water supply. Vacuum lines should be protected with liquid disinfectant traps and HEPA filters, or their equivalent. Alternative vacuum pumps should also be properly protected with traps and filters.
14. The containment laboratory – Biosafety Level 3 facility design and operational procedures should be documented.

An example of laboratory design for Biosafety Level 3 is shown in Figure 4.

### **Laboratory equipment**

The principles for the selection of laboratory equipment, including biological safety cabinets (see Chapter 10) are the same as for the basic laboratory – Biosafety Level 2. However, at Biosafety Level 3, manipulation of all potentially infectious material must be conducted within a biological safety cabinet or other primary containment device. Consideration should be given to equipment such as centrifuges, which will need additional containment accessories, for example, safety buckets or containment rotors. Some centrifuges and other equipment, such as cell-sorting instruments for use with infected cells, may need additional local exhaust ventilation with HEPA filtration for efficient containment.

### **Health and medical surveillance**

The objectives of health and medical surveillance programmes for basic laboratories – Biosafety Levels 1 and 2 also apply to containment laboratories – Biosafety Level 3, except where modified as follows:

1. Medical examination of all laboratory personnel who work in containment laboratories – Biosafety Level 3 is mandatory. This should include recording of a detailed medical history and an occupationally-targeted physical examination.
2. After a satisfactory clinical assessment, the examinee may be provided with a medical contact card (e.g. as shown in Figure 5) stating that he or she is employed in a facility with a containment laboratory – Biosafety Level 3. This card should include

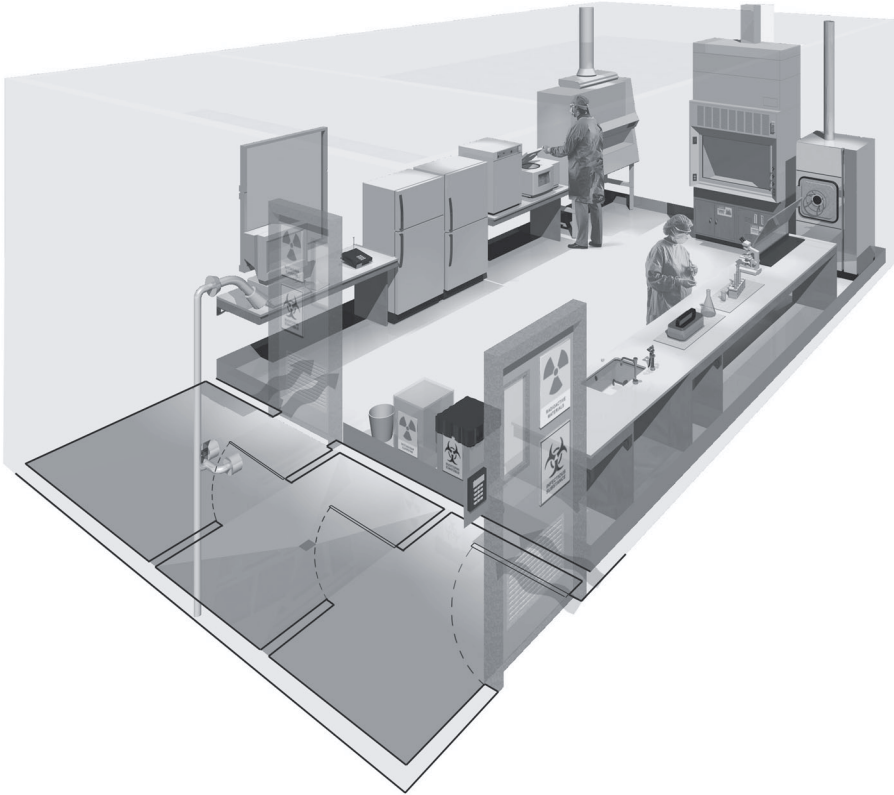

**Figure 4. A typical Biosafety Level 3 laboratory**

*(graphics kindly provided by CUH2A, Princeton, NJ, USA). The laboratory is separated from general traffic flow and accessed through an anteroom (double door entry or basic laboratory – Biosafety Level 2) or an airlock. An autoclave is available within the facility for decontamination of wastes prior to disposal. A sink with hands-free operation is available. Inward directional airflow is established and all work with infectious materials is conducted within a biological safety cabinet.*

a picture of the card holder, be wallet-sized, and always be carried by the holder. The name(s) of the contact persons to be entered will need to be agreed locally but might include the laboratory director, medical adviser and/or biosafety officer.

**A. Front of card**

ILLNESS SURVEILLANCE NOTICE		<i>Card holder's picture</i>
Name		
<p>TO THE EMPLOYEE</p> <p>Keep this card in your possession. In case of unexplained febrile illness, present the card to your physician and notify one of the following in the order listed.</p>		
Dr	Tel (Work):	
	Tel (Home):	
Dr	Tel (Work):	
	Tel (Home):	

**B. Back of card**

<p>TO THE PHYSICIAN</p> <p>The holder of this card works in an area at _____ in which pathogenic viruses, rickettsia, bacteria, protozoa or helminths are present. In the event of an unexplained febrile illness, please call the employer for information on agents to which this employee may have been exposed.</p> <p>Name of laboratory: _____</p> <p>Address: _____</p> <p>_____</p> <p>_____</p> <p>_____</p> <p>Tel: _____</p>
---

Figure 5. Suggested format for medical contact card



# 5. The maximum containment laboratory – Biosafety Level 4

The maximum containment laboratory – Biosafety Level 4 is designed for work with Risk Group 4 microorganisms. Before such a laboratory is constructed and put into operation, intensive consultations should be held with institutions that have had experience of operating a similar facility. Operational maximum containment laboratories – Biosafety Level 4 should be under the control of national or other appropriate health authorities. The following information is intended only as introductory material. Entities working to pursue development of a Biosafety Level 4 laboratory should contact the WHO Biosafety programme for additional information.<sup>1</sup>

## Code of practice

The code of practice for Biosafety Level 3 applies except where modified as follows:

1. The two-person rule should apply, whereby no individual ever works alone. This is particularly important if working in a Biosafety Level 4 suit facility.
2. A complete change of clothing and shoes is required prior to entering and upon exiting the laboratory.
3. Personnel must be trained in emergency extraction procedures in the event of personnel injury or illness.
4. A method of communication for routine and emergency contacts must be established between personnel working within the maximum containment laboratory – Biosafety Level 4 and support personnel outside the laboratory.

## Laboratory design and facilities

The features of a containment laboratory – Biosafety Level 3 also apply to a maximum containment laboratory – Biosafety Level 4 with the addition of the following.

1. **Primary containment.** An efficient primary containment system must be in place, consisting of one or a combination of the following.
  - *Class III cabinet laboratory.* Passage through a minimum of two doors prior to entering the rooms containing the Class III biological safety cabinet(s) (cabinet room) is required. In this laboratory configuration the Class III biological safety

---

<sup>1</sup> Biosafety programme, Department of Communicable Disease Surveillance and Response, World Health Organization, 20 Avenue Appia, 1211 Geneva 27, Switzerland (<http://www.who.int/csr/>).

cabinet provides the primary containment. A personnel shower with inner and outer changing rooms is necessary. Supplies and materials that are not brought into the cabinet room through the changing area are introduced through a double-door autoclave or fumigation chamber. Once the outer door is securely closed, staff inside the laboratory can open the inner door to retrieve the materials. The doors of the autoclave or fumigation chamber are interlocked in such a way that the outer door cannot open unless the autoclave has been operated through a sterilization cycle or the fumigation chamber has been decontaminated (see Chapter 10).

- *Suit laboratory.* A protective suit laboratory with self-contained breathing apparatus differs significantly in design and facility requirements from a Biosafety Level 4 laboratory with Class III biological safety cabinets. The rooms in the protective suit laboratory are arranged so as to direct personnel through the changing and decontamination areas prior to entering areas where infectious materials are manipulated. A suit decontamination shower must be provided and used by personnel leaving the containment laboratory area. A separate personnel shower with inner and outer changing rooms is also provided. Personnel who enter the suit area are required to don a one-piece, positively pressurized, HEPA-filtered, supplied-air suit. Air to the suit must be provided by a system that has a 100% redundant capability with an independent source of air, for use in the event of an emergency. Entry into the suit laboratory is through an airlock fitted with airtight doors. An appropriate warning system for personnel working in the suit laboratory must be provided for use in the event of mechanical system or air failure (see Chapter 10).
2. **Controlled access.** The maximum containment laboratory – Biosafety Level 4 must be located in a separate building or in a clearly delineated zone within a secure building. Entry and exit of personnel and supplies must be through an airlock or pass-through system. On entering, personnel must put on a complete change of clothing; before leaving, they should shower before putting on their street clothing.
  3. **Controlled air system.** Negative pressure must be maintained in the facility. Both supply and exhaust air must be HEPA-filtered. There are significant differences in the ventilating systems of the Class III cabinet laboratory and suit laboratory:
    - *Class III cabinet laboratory.* The supply air to the Class III biological safety cabinet(s) may be drawn from within the room through a HEPA filter mounted on the cabinet or supplied directly through the supply air system. Exhaust air from the Class III biological safety cabinet must pass through two HEPA filters prior to release outdoors. The cabinet must be operated at negative pressure to the surrounding laboratory at all times. A dedicated non-recirculating ventilating system for the cabinet laboratory is required.
    - *Suit laboratory.* Dedicated room air supply and exhaust systems are required. The supply and exhaust components of the ventilating system are balanced to provide directional airflow within the suit area from the area of least hazard to

the area(s) of greatest potential hazard. Redundant exhaust fans are required to ensure that the facility remains under negative pressure at all times. The differential pressures within the suit laboratory and between the suit laboratory and adjacent areas must be monitored. Airflow in the supply and exhaust components of the ventilating system must be monitored, and an appropriate system of controls must be used to prevent pressurization of the suit laboratory. HEPA-filtered supply air must be provided to the suit area, decontamination shower and decontamination airlocks or chambers. Exhaust air from the suit laboratory must be passed through a series of two HEPA filters prior to release outdoors. Alternatively, after double HEPA filtration, exhaust air may be recirculated, but only within the suit laboratory. Under no circumstances shall the exhaust air from the Biosafety Level 4 suit laboratory be recirculated to other areas. Extreme caution must be exercised if recirculation of air within the suit laboratory is elected. Consideration must be given to the types of research conducted, equipment, chemicals and other materials used in the suit laboratory, as well as animal species that may be involved in the research.

All HEPA filters need to be tested and certified annually. The HEPA filter housings are designed to allow for in situ decontamination of the filter prior to removal. Alternatively, the filter can be removed in a sealed, gas-tight primary container for subsequent decontamination and/or destruction by incineration.

4. **Decontamination of effluents.** All effluents from the suit area, decontamination chamber, decontamination shower, or Class III biological safety cabinet must be decontaminated before final discharge. Heat treatment is the preferred method. Effluents may also require correction to a neutral pH prior to discharge. Water from the personnel shower and toilet may be discharged directly to the sanitary sewer without treatment.
5. **Sterilization of waste and materials.** A double-door, pass-through autoclave must be available in the laboratory area. Other methods of decontamination must be available for equipment and items that cannot withstand steam sterilization.
6. **Airlock entry ports** for specimens, materials and animals must be provided.
7. **Emergency power** and dedicated power supply line(s) must be provided.
8. **Containment drain(s)** must be installed.

Because of the great complexity of the engineering, design and construction of Biosafety Level 4 facilities, in either cabinet or suit configuration, schematic representations of such facilities have not been included.

Because of the great complexity of the work in the Biosafety Level 4 laboratory, a separate detailed work manual should be developed and tested in training exercises. In addition, an emergency programme must be devised (see Chapter 13). In the preparation of this programme, active cooperation with national and local health authorities should be established. Other emergency services, e.g. fire, police and designated receiving hospitals, should also be involved.

# 6. Laboratory animal facilities

Those who use animals for experimental and diagnostic purposes have a moral obligation to take every care to avoid causing them unnecessary pain or suffering. The animals must be provided with comfortable, hygienic housing and adequate wholesome food and water. At the end of the experiment they must be dealt with in a humane manner.

For security reasons, the animal house should be an independent, detached unit. If it adjoins a laboratory, the design should provide for its isolation from the public parts of the laboratory should such need arise, and for its decontamination and disinfection.

**Table 4. Animal facility containment levels: summary of practices and safety equipment**

RISK GROUP	CONTAINMENT LEVEL	LABORATORY PRACTICES AND SAFETY EQUIPMENT
1	ABSL-1	Limited access, protective clothing and gloves.
2	ABSL-2	ABSL-1 practices plus: hazard warning signs. Class I or II BSCs for activities that produce aerosols. Decontamination of waste and cages before washing.
3	ABSL-3	ABSL-2 practices plus: controlled access. BSCs and special protective clothing for all activities.
4	ABSL-4	ABSL-3 plus: strictly limited access. Clothing change before entering. Class III BSCs or positive pressure suits. Shower on exit. Decontamination of all wastes before removal from facility.

ABSL, animal facility Biosafety Level; BSCs, biological safety cabinets

Animal facilities, like laboratories, may be designated according to a risk assessment and the risk group of the microorganisms under investigation, as Animal facility Biosafety Level 1, 2, 3 or 4.

With respect to agents to be used in the animal laboratory, factors for consideration include:

1. The normal route of transmission

2. The volumes and concentrations to be used
3. The route of inoculation
4. Whether and by what route these agents may be excreted.

With respect to animals to be used in the animal laboratory, factors for consideration include:

1. The nature of the animals, i.e. their aggressiveness and tendency to bite and scratch
2. Their natural ecto- and endoparasites
3. The zoonotic diseases to which they are susceptible
4. The possible dissemination of allergens.

As with laboratories, the requirements for design features, equipment and precautions increase in stringency according to the animal biosafety level. These are described below and summarized in Table 4. These guidelines are additive, so that each higher level incorporates the standards of the lower levels.

### **Animal facility – Biosafety Level 1**

This is suitable for the maintenance of most stock animals after quarantine (except nonhuman primates, regarding which national authorities should be consulted), and for animals that are deliberately inoculated with agents in Risk Group 1. GMT are required. The animal facility director must establish policies, procedures and protocols for all operations, and for access to the vivarium. An appropriate medical surveillance programme for the staff must be instituted. A safety or operations manual must be prepared and adopted.

### **Animal facility – Biosafety Level 2**

This is suitable for work with animals that are deliberately inoculated with micro-organisms in Risk Group 2. The following safety precautions apply:

1. All the requirements for animal facilities – Biosafety Level 1 must be met.
2. Biohazard warning signs (see Figure 1) should be posted on doors and other appropriate places.
3. The facility must be designed for easy cleaning and housekeeping.
4. Doors must open inwards and be self-closing.
5. Heating, ventilation and lighting must be adequate.
6. If mechanical ventilation is provided, the airflow must be inwards. Exhaust air is discharged to the outside and should not be recirculated to any part of the building.
7. Access must be restricted to authorized persons.
8. No animals should be admitted other than those for experimental use.
9. There should be an arthropod and rodent control programme.
10. Windows, if present, must be secure, resistant to breakage and, if able to be opened, must be fitted with arthropod-proof screens.
11. After use, work surfaces must be decontaminated with effective disinfectants (see Chapter 14).

12. Biological safety cabinets (Classes I or II) or isolator cages with dedicated air supplies and HEPA-filtered exhaust air must be provided for work that may involve the generation of aerosols.
13. An autoclave must be available on site or in appropriate proximity to the animal facility.
14. Animal bedding materials must be removed in a manner that minimizes the generation of aerosols and dust.
15. All waste materials and bedding must be decontaminated before disposal.
16. Use of sharp instruments should be restricted whenever possible. Sharps should always be collected in puncture-proof/-resistant containers fitted with covers and treated as infectious.
17. Material for autoclaving or incineration must be transported safely, in closed containers.
18. Animal cages must be decontaminated after use.
19. Animal carcasses should be incinerated.
20. Protective clothing and equipment must be worn in the facility, and removed on leaving.
21. Hand-washing facilities must be provided. Staff must wash their hands before leaving the animal facility.
22. All injuries, however minor, must be treated appropriately, reported and recorded.
23. Eating, drinking, smoking and application of cosmetics must be forbidden in the facility.
24. All personnel must receive appropriate training.

### **Animal facility – Biosafety Level 3**

This is suitable for work with animals that are deliberately inoculated with agents in Risk Group 3, or when otherwise indicated by a risk assessment. All systems, practices and procedures need to be reviewed and recertified annually. The following safety precautions apply:

1. All the requirements for animal facilities – Biosafety Levels 1 and 2 must be met.
2. Access must be strictly controlled.
3. The facility must be separated from other laboratory and animal house areas by a room with a double-door entrance forming an anteroom.
4. Hand-washing facilities must be provided in the anteroom.
5. Showers should be provided in the anteroom.
6. There must be mechanical ventilation to ensure a continuous airflow through all the rooms. Exhaust air must pass through HEPA filters before being discharged to the atmosphere without recirculation. The system must be designed to prevent accidental reverse flow and positive pressurization in any part of the animal house.
7. An autoclave must be available at a location convenient for the animal house where the biohazard is contained. Infectious waste should be autoclaved before it is moved to other areas of the facility.

8. An incinerator should be readily available on site or alternative arrangements should be made with the authorities concerned.
9. Animals infected with Risk Group 3 microorganisms must be housed in cages in isolators or rooms with ventilation exhausts placed behind the cages.
10. Bedding should be as dust-free as possible.
11. All protective clothing must be decontaminated before it is laundered.
12. Windows must be closed and sealed, and resistant to breakage.
13. Immunization of staff, as appropriate, should be offered.

#### **Animal facility – Biosafety Level 4**

Work in this facility will normally be linked with that in the maximum containment laboratory – Biosafety Level 4, and national and local rules and regulations must be harmonized to apply to both. If work is to be done in a suit laboratory, additional practices and procedures must be used over and above those described here (see Chapter 5).

1. All the requirements for animal facilities – Biosafety Levels 1, 2 and 3 must be met.
2. Access must be strictly controlled; only staff designated by the director of the establishment should have authority to enter.
3. Individuals must not work alone: the two-person rule must apply.
4. Personnel must have received the highest possible level of training as microbiologists and be familiar with the hazards involved in their work and with the necessary precautions.
5. Housing areas for animals infected with Risk Group 4 agents must maintain the criteria for containment described and applied for maximum containment laboratories – Biosafety Level 4.
6. The facility must be entered by an airlock anteroom, the clean side of which must be separated from the restricted side by changing and showering facilities.
7. Staff must remove street clothing when entering and put on special, protective clothing. After work they must remove the protective clothing for autoclaving, and shower before leaving.
8. The facility must be ventilated by a HEPA-filtered exhaust system designed to ensure a negative pressure (inward directional airflow).
9. The ventilation system must be designed to prevent reverse flow and positive-pressurization.
10. A double-ended autoclave with the clean end in a room outside the containment rooms must be provided for exchange of materials.
11. A pass-through airlock with the clean end in a room outside the containment rooms must be provided for exchange of non-autoclavable materials.
12. All manipulations with animals infected with Risk Group 4 agents must take place under maximum containment – Biosafety Level 4 conditions.
13. All animals must be housed in isolators.
14. All animal bedding and waste must be autoclaved before removal from the facility.

15. There must be medical supervision of staff.

### **Invertebrates**

As with vertebrates, the animal facility biosafety level will be determined by the risk groups of the agents under investigation or when otherwise indicated by a risk assessment. The following additional precautions are necessary with certain arthropods, particularly with flying insects:

1. Separate rooms should be provided for infected and noninfected invertebrates.
2. The rooms should be capable of being sealed for fumigation.
3. Insecticide sprays should be readily available.
4. “Chilling” facilities should be provided to reduce, where necessary, the activity of invertebrates.
5. Access should be through an anteroom containing insect traps and with arthropod-proof screens on the doors.
6. All exhaust ventilation ducts and openable windows should be fitted with arthropod-proof screens.
7. Waste traps on sinks and sluices should not be allowed to dry out.
8. All waste should be decontaminated by autoclaving, as some invertebrates are not killed by all disinfectants.
9. A check should be kept on the numbers of larval and adult forms of flying, crawling and jumping arthropods.
10. Containers for ticks and mites should stand in trays of oil.
11. Infected or potentially infected flying insects must be contained in double-netted cages.
12. Infected or potentially infected arthropods must be handled in biological safety cabinets or isolators.
13. Infected or potentially infected arthropods may be manipulated on cooling trays.

For further information see references (3–6).



# 7. Guidelines for laboratory/facility commissioning

Laboratory/facility commissioning may be defined as the systematic review and documentation process signifying that specified laboratory structural components, systems and/or system components have been installed, inspected, functionally tested and verified to meet national or international standards, as appropriate. The respective building system's design criteria and design function establish these requirements. In other words, laboratories designated as Biosafety Levels 1–4 will have different and increasingly complex commissioning requirements. Geographical and climatic conditions, such as geological fault lines or extreme heat, cold or humidity may also affect the laboratory design and therefore the commissioning requirements. Upon the completion of the commissioning process, the pertinent structural components and support systems will have been subjected to the various operating conditions and failure modes that can be reasonably expected, and will have been approved.

The commissioning process and acceptance criteria should be established early, preferably during the programming phase of the construction or renovation project. By acknowledging the commissioning process early in the project, architects, engineers, safety and health personnel and ultimately the laboratory occupants understand the performance requirements of the specific laboratory and set uniform expectations for laboratory and/or facility performance. The commissioning process provides the institution and the surrounding community with a greater degree of confidence that the structural, electrical, mechanical and plumbing systems, containment and decontamination systems, and security and alarm systems will operate as designed, to assure containment of any potentially dangerous microorganisms being worked with in a particular laboratory or animal facility.

Commissioning activities generally begin during the programming phase of the project and proceed through the construction and subsequent warranty period for the laboratory/facility. Warranty periods should generally extend for one year following occupancy. It is recommended that a commissioning agent is retained who is independent of the architectural, engineering and construction firms involved in the design and construction. The commissioning agent serves as an advocate for the institution constructing or renovating the laboratory and should be considered as a member of the design team; involvement of the agent in the early programming phase of the project is essential. In some cases, the institution may act as its own commissioning agent. In the case of more complex laboratory facilities (Biosafety

Levels 3 or 4), the institution may wish to retain an outside commissioning agent who has demonstrated experience and success in the commissioning of complex biosafety laboratory and animal facilities. When an independent commissioning agent is used, the institution should still be a member of the commissioning team. It is recommended that, in addition to the commissioning agent, the institution's Safety Officer, Project Officer, Programme Manager and a representative of the Operations and Maintenance staff are also part of the team.

The following is a list of laboratory systems and components that may be included in a commissioning plan for functional testing, depending on the containment level of the facility being renovated or constructed. The list is not exhaustive. Obviously, the actual commissioning plan will reflect the complexity of the laboratory being planned.

1. Building automation systems including links to remote monitoring and control sites
2. Electronic surveillance and detection systems
3. Electronic security locks and proximity device readers
4. Heating, ventilation (supply and exhaust) and air-conditioning (HVAC) systems
5. High-efficiency particulate air (HEPA) filtration systems
6. HEPA decontamination systems
7. HVAC and exhaust air system controls and control interlocks
8. Airtight isolation dampers
9. Laboratory refrigeration systems
10. Boilers and steam systems
11. Fire detection, suppression and alarm systems
12. Domestic water backflow prevention devices
13. Processed water systems (i.e. reverse osmosis, distilled water)
14. Liquid effluent treatment and neutralization systems
15. Plumbing drain primer systems
16. Chemical decontaminant systems
17. Medical laboratory gas systems
18. Breathing air systems
19. Service and instrument air systems
20. Cascading pressure differential verification of laboratories and support areas
21. Local area network (LAN) and computer data systems
22. Normal power systems
23. Emergency power systems
24. Uninterruptible power systems
25. Emergency lighting systems
26. Lighting fixture penetration seals
27. Electrical and mechanical penetration seals
28. Telephone systems

29. Airlock door control interlocks
30. Airtight door seals
31. Window and vision-panel penetration seals
32. Barrier pass-through penetration
33. Structural integrity verification: concrete floors, walls and ceilings
34. Barrier coating verification: floors, walls and ceilings
35. Biosafety Level 4 containment envelope pressurization and isolation functions
36. Biological safety cabinets
37. Autoclaves
38. Liquid nitrogen system and alarms
39. Water detection systems (e.g. in case of flooding inside containment zone)
40. Decontamination shower and chemical additive systems
41. Cage-wash and neutralization systems
42. Waste management.

# 8. Guidelines for laboratory/facility certification

Laboratories are complex and dynamic environments. Today's biomedical research and clinical laboratories must be able to adapt quickly to continuously increasing public health needs and pressures. An example of this is the need for laboratories to adjust priorities to meet the challenges of emerging or re-emerging infectious diseases. In order to assure that adaptation and maintenance are undertaken promptly and in an appropriate and safe manner, all biological research and clinical laboratories should be regularly certified. Laboratory certification helps to ensure that:

1. Proper engineering controls are being used and are functioning adequately as designed
2. Appropriate site and protocol specific administrative controls are in place
3. Personal protective equipment is appropriate for the tasks being performed
4. Decontamination of waste and materials has been adequately considered and proper waste management procedures are in place
5. Proper procedures for general laboratory safety, including physical, electrical and chemical safety are in place.

Laboratory certification differs from laboratory commissioning activities (Chapter 7) in several important ways. Laboratory certification is the systematic examination of all safety features and processes within the laboratory (engineering controls, personal protective equipment and administrative controls). Biosafety practices and procedures are also examined. Laboratory certification is an on-going quality and safety assurance activity that should take place on a regular basis.

Adequately trained safety and health or biosafety professionals may conduct laboratory certification activities. Institutions may employ personnel having the appropriate skill-set required for conducting audits, surveys or inspections (these terms are used interchangeably) associated with the certification process. However, institutions may consider engaging or be required to engage a third party to provide these services.

Biomedical research and clinical laboratory facilities may develop audit, survey or inspection tools to help ensure consistency in the certification process. These tools should be flexible enough to allow for the physical and procedural differences between laboratories necessitated by the type of work being conducted, while at the same time providing a consistent approach within the institution. Care must be taken to ensure

that these tools are used only by appropriately trained personnel, and that they are not used as a substitute for a sound professional biosafety assessment. Examples of such tools are provided in Tables 5–7.

Findings of the audit, survey or inspection should be discussed with laboratory personnel and management. Within the laboratory, an individual should be identified and made responsible for ensuring that corrective actions are taken for all deficiencies identified during the audit process. Certification of the laboratory should not be completed, and the laboratory should not be declared functional, until deficiencies have been adequately addressed.

The complexity of Biosafety Level 4 laboratory operations goes beyond the scope of this manual. For details and further information, please contact the WHO Biosafety programme<sup>1</sup> (see also Annex 3).

---

<sup>1</sup> WHO Biosafety programme, Department of Communicable Disease Surveillance and Response, World Health Organization, 20 Avenue Appia, 1211 Geneva 27, Switzerland (<http://www.who.int/csr/>).

**Table 5. Basic Laboratory – Biosafety Level 1: laboratory safety survey**

Location . . . . . Date . . . . .  
 Person in charge of laboratory . . . . .

CHECKED ITEM (ENTER DATE OF CHECK)	YES	NO	N/A	COMMENTS
<b>Laboratory</b>				Biosafety Level: <i>Attach the appropriate Biosafety Level Survey Form</i>
Proper signage: ultraviolet light, laser, radioactive material, etc. ....	<input type="checkbox"/>	<input type="checkbox"/>	<input type="checkbox"/>	
Appropriate biosafety guidelines available and followed .....	<input type="checkbox"/>	<input type="checkbox"/>	<input type="checkbox"/>	
Laboratory equipment properly labelled (biohazardous, radioactive, toxic, etc.) ..	<input type="checkbox"/>	<input type="checkbox"/>	<input type="checkbox"/>	
<b>Laboratory design</b>				
Designed for easy cleaning .....	<input type="checkbox"/>	<input type="checkbox"/>	<input type="checkbox"/>	
Room ultraviolet lights on interlock switch	<input type="checkbox"/>	<input type="checkbox"/>	<input type="checkbox"/>	
All shelves secured .....	<input type="checkbox"/>	<input type="checkbox"/>	<input type="checkbox"/>	
Bench-tops waterproof and resistant to acids, alkali, organic solvents and heat .	<input type="checkbox"/>	<input type="checkbox"/>	<input type="checkbox"/>	
Adequate illumination provided .....	<input type="checkbox"/>	<input type="checkbox"/>	<input type="checkbox"/>	
Adequate storage space available and appropriately used .....	<input type="checkbox"/>	<input type="checkbox"/>	<input type="checkbox"/>	
<b>Gas cylinders</b>				
All cylinders secured .....	<input type="checkbox"/>	<input type="checkbox"/>	<input type="checkbox"/>	
Caps on reserve cylinders .....	<input type="checkbox"/>	<input type="checkbox"/>	<input type="checkbox"/>	
Asphyxiating and hazardous gases only in ventilated rooms .....	<input type="checkbox"/>	<input type="checkbox"/>	<input type="checkbox"/>	
Excess or empty cylinders present .....	<input type="checkbox"/>	<input type="checkbox"/>	<input type="checkbox"/>	
<b>Chemicals</b>				
Flammables stored in flammable storage cabinet .....	<input type="checkbox"/>	<input type="checkbox"/>	<input type="checkbox"/>	
Peroxide formers double-dated (received and opened) .....	<input type="checkbox"/>	<input type="checkbox"/>	<input type="checkbox"/>	
Chemicals properly segregated .....	<input type="checkbox"/>	<input type="checkbox"/>	<input type="checkbox"/>	
Hazardous chemicals stored above eye level .....	<input type="checkbox"/>	<input type="checkbox"/>	<input type="checkbox"/>	
Chemicals stored on the floor .....	<input type="checkbox"/>	<input type="checkbox"/>	<input type="checkbox"/>	
Chemical containers left open .....	<input type="checkbox"/>	<input type="checkbox"/>	<input type="checkbox"/>	
All solutions properly labelled .....	<input type="checkbox"/>	<input type="checkbox"/>	<input type="checkbox"/>	
Mercury thermometers in use .....	<input type="checkbox"/>	<input type="checkbox"/>	<input type="checkbox"/>	
<b>Refrigerators/freezers/cold rooms</b>				
Food for human consumption present .....	<input type="checkbox"/>	<input type="checkbox"/>	<input type="checkbox"/>	
Flammables in explosion-proof/-safe units	<input type="checkbox"/>	<input type="checkbox"/>	<input type="checkbox"/>	
Labelled externally if containing carcinogens, radioactivity and/or biohazards .....	<input type="checkbox"/>	<input type="checkbox"/>	<input type="checkbox"/>	
Cold-room has emergency release .....	<input type="checkbox"/>	<input type="checkbox"/>	<input type="checkbox"/>	

8. GUIDELINES FOR LABORATORY/FACILITY CERTIFICATION

CHECKED ITEM (ENTER DATE OF CHECK)	YES	NO	N/A	COMMENTS
<b>Electrical equipment</b>				
Extension cords present .....	<input type="checkbox"/>	<input type="checkbox"/>	<input type="checkbox"/>	
Outlets earthed/grounded and with proper polarity .....	<input type="checkbox"/>	<input type="checkbox"/>	<input type="checkbox"/>	
Connections by sinks, under showers, etc. ....	<input type="checkbox"/>	<input type="checkbox"/>	<input type="checkbox"/>	
Equipment with frayed or damaged wiring .....	<input type="checkbox"/>	<input type="checkbox"/>	<input type="checkbox"/>	
Overloaded outlets or electrical strips .....	<input type="checkbox"/>	<input type="checkbox"/>	<input type="checkbox"/>	
Power strips mounted off the floor .....	<input type="checkbox"/>	<input type="checkbox"/>	<input type="checkbox"/>	
Proper fuses in conduits .....	<input type="checkbox"/>	<input type="checkbox"/>	<input type="checkbox"/>	
Electrical outlets near water sources meet local codes .....	<input type="checkbox"/>	<input type="checkbox"/>	<input type="checkbox"/>	
Earths/grounds present on electrical cords	<input type="checkbox"/>	<input type="checkbox"/>	<input type="checkbox"/>	
Portable space heaters .....	<input type="checkbox"/>	<input type="checkbox"/>	<input type="checkbox"/>	
<b>Personal protective equipment</b>				
Eyewash available in laboratory .....	<input type="checkbox"/>	<input type="checkbox"/>	<input type="checkbox"/>	
Safety shower available .....	<input type="checkbox"/>	<input type="checkbox"/>	<input type="checkbox"/>	
Personal protective equipment available (gloves, gowns, goggles, etc.) .....	<input type="checkbox"/>	<input type="checkbox"/>	<input type="checkbox"/>	
Occupants properly attired .....	<input type="checkbox"/>	<input type="checkbox"/>	<input type="checkbox"/>	
Laboratory coats, gowns, smocks, gloves and other personal protective clothing not worn outside the laboratory .....	<input type="checkbox"/>	<input type="checkbox"/>	<input type="checkbox"/>	
Personal protective equipment available for cryogenic storage .....	<input type="checkbox"/>	<input type="checkbox"/>	<input type="checkbox"/>	
<b>Waste management</b>				
Evidence of improper waste disposal .....	<input type="checkbox"/>	<input type="checkbox"/>	<input type="checkbox"/>	
Wastes segregated in proper containers ....	<input type="checkbox"/>	<input type="checkbox"/>	<input type="checkbox"/>	
Chemical waste containers tagged, labelled, dated and kept closed .....	<input type="checkbox"/>	<input type="checkbox"/>	<input type="checkbox"/>	
Chemical waste containers appropriately handled and stored .....	<input type="checkbox"/>	<input type="checkbox"/>	<input type="checkbox"/>	
Sharps containers used and disposed of properly .....	<input type="checkbox"/>	<input type="checkbox"/>	<input type="checkbox"/>	
No trash on floor .....	<input type="checkbox"/>	<input type="checkbox"/>	<input type="checkbox"/>	
Waste disposal procedures posted in laboratory .....	<input type="checkbox"/>	<input type="checkbox"/>	<input type="checkbox"/>	
<b>Occupational health and safety programmes available</b>				
Hazard communication .....	<input type="checkbox"/>	<input type="checkbox"/>	<input type="checkbox"/>	
Respiratory protection .....	<input type="checkbox"/>	<input type="checkbox"/>	<input type="checkbox"/>	
Hearing conservation .....	<input type="checkbox"/>	<input type="checkbox"/>	<input type="checkbox"/>	
Formaldehyde monitoring .....	<input type="checkbox"/>	<input type="checkbox"/>	<input type="checkbox"/>	
Ethylene oxide monitoring .....	<input type="checkbox"/>	<input type="checkbox"/>	<input type="checkbox"/>	
Anaesthetic gas monitoring .....	<input type="checkbox"/>	<input type="checkbox"/>	<input type="checkbox"/>	

CHECKED ITEM (ENTER DATE OF CHECK)	YES	NO	N/A	COMMENTS
<b>General engineering controls</b>				
Laboratory airflow is negative to general occupancy, corridor and office areas .....	<input type="checkbox"/>	<input type="checkbox"/>	<input type="checkbox"/>	
Cup sinks or drains acting as vents .....	<input type="checkbox"/>	<input type="checkbox"/>	<input type="checkbox"/>	
Sink available for hand-washing .....	<input type="checkbox"/>	<input type="checkbox"/>	<input type="checkbox"/>	
Exposed machine parts (pulleys, gears) .....	<input type="checkbox"/>	<input type="checkbox"/>	<input type="checkbox"/>	
Vacuum line has filters and traps on laboratory benches .....	<input type="checkbox"/>	<input type="checkbox"/>	<input type="checkbox"/>	
Backflow hazards to water supply .....	<input type="checkbox"/>	<input type="checkbox"/>	<input type="checkbox"/>	
Distilled water systems in good condition ..	<input type="checkbox"/>	<input type="checkbox"/>	<input type="checkbox"/>	
Active and effective arthropod and rodent control programme .....	<input type="checkbox"/>	<input type="checkbox"/>	<input type="checkbox"/>	
<b>General practices and procedures</b>				
Food for human consumption stored outside the laboratory .....	<input type="checkbox"/>	<input type="checkbox"/>	<input type="checkbox"/>	
Microwave oven(s) clearly labelled "No Food Preparation, Laboratory Use Only"	<input type="checkbox"/>	<input type="checkbox"/>	<input type="checkbox"/>	
Eating, drinking, smoking and/or applying of cosmetics occurring in the laboratory	<input type="checkbox"/>	<input type="checkbox"/>	<input type="checkbox"/>	
Pressurized glass containers taped or shielded (i.e. vacuum traps) .....	<input type="checkbox"/>	<input type="checkbox"/>	<input type="checkbox"/>	
Mouth pipetting prohibited .....	<input type="checkbox"/>	<input type="checkbox"/>	<input type="checkbox"/>	
Mechanical pipetting devices available and used .....	<input type="checkbox"/>	<input type="checkbox"/>	<input type="checkbox"/>	
Protective laboratory clothing stored separately from street clothing .....	<input type="checkbox"/>	<input type="checkbox"/>	<input type="checkbox"/>	
<b>General laboratory housekeeping</b>				
Glass containers stored on the floor .....	<input type="checkbox"/>	<input type="checkbox"/>	<input type="checkbox"/>	
Trip hazards evident .....	<input type="checkbox"/>	<input type="checkbox"/>	<input type="checkbox"/>	
Clean absorbent pads on work surfaces .....	<input type="checkbox"/>	<input type="checkbox"/>	<input type="checkbox"/>	
Broken glassware handled by mechanical means (brush and dustpan, tongs, etc.)	<input type="checkbox"/>	<input type="checkbox"/>	<input type="checkbox"/>	
<b>Fire protection</b>				
Sprinkler heads free and unobstructed .....	<input type="checkbox"/>	<input type="checkbox"/>	<input type="checkbox"/>	
Open penetrations in walls, ceiling, floor, etc.	<input type="checkbox"/>	<input type="checkbox"/>	<input type="checkbox"/>	
Wiring or tubing through door openings .....	<input type="checkbox"/>	<input type="checkbox"/>	<input type="checkbox"/>	
Minimum passage width of 1 m in laboratory	<input type="checkbox"/>	<input type="checkbox"/>	<input type="checkbox"/>	
Storage observed on ductwork or light fixtures	<input type="checkbox"/>	<input type="checkbox"/>	<input type="checkbox"/>	
Excess combustibles stored in laboratory ..	<input type="checkbox"/>	<input type="checkbox"/>	<input type="checkbox"/>	
<b>Heated constant temperature baths</b>				
Equipped with low water level and overheat shutoff .....	<input type="checkbox"/>	<input type="checkbox"/>	<input type="checkbox"/>	
Constructed of noncombustible materials ..	<input type="checkbox"/>	<input type="checkbox"/>	<input type="checkbox"/>	

Safety surveyor's signature: . . . . . Date survey completed: . . . . .



Table 6. **Basic laboratory – Biosafety Level 2: laboratory safety survey.**

*This form is used in conjunction with the Biosafety Level 1 laboratory safety survey form*

---

Location . . . . . Date . . . . .

Person in charge of laboratory . . . . .

---

CHECKED ITEM (ENTER DATE OF CHECK)	YES	NO	N/A	COMMENTS
<b>Biological safety cabinet (BSC)</b>				Date:
Certification within last year .....	<input type="checkbox"/>	<input type="checkbox"/>	<input type="checkbox"/>	Location:
BSC surface wiped down with appropriate disinfectant at beginning and end of each procedure .....	<input type="checkbox"/>	<input type="checkbox"/>	<input type="checkbox"/>	Brand:
Front grill and exhaust filter unobstructed ..	<input type="checkbox"/>	<input type="checkbox"/>	<input type="checkbox"/>	Type:
Open flames used inside cabinet .....	<input type="checkbox"/>	<input type="checkbox"/>	<input type="checkbox"/>	Serial no.:
Vacuum lines have in-line filters and disinfectant traps in use .....	<input type="checkbox"/>	<input type="checkbox"/>	<input type="checkbox"/>	
BSC compromised by room air or location	<input type="checkbox"/>	<input type="checkbox"/>	<input type="checkbox"/>	
BSC used when there is potential for creating aerosols .....	<input type="checkbox"/>	<input type="checkbox"/>	<input type="checkbox"/>	
<b>Laboratory</b>				
Access limited and restricted to authorized personnel .....	<input type="checkbox"/>	<input type="checkbox"/>	<input type="checkbox"/>	
Entry limited to personnel advised of all potential hazards .....	<input type="checkbox"/>	<input type="checkbox"/>	<input type="checkbox"/>	
Biohazard sign posted on laboratory door as appropriate .....	<input type="checkbox"/>	<input type="checkbox"/>	<input type="checkbox"/>	
• Information on sign accurate and current .....	<input type="checkbox"/>	<input type="checkbox"/>	<input type="checkbox"/>	
• Sign legible and not defaced .....	<input type="checkbox"/>	<input type="checkbox"/>	<input type="checkbox"/>	
All doors closed .....	<input type="checkbox"/>	<input type="checkbox"/>	<input type="checkbox"/>	
<b>Decontamination</b>				
Decontaminant specific to the organism(s) in use .....	<input type="checkbox"/>	<input type="checkbox"/>	<input type="checkbox"/>	
All spills and accidents involving infectious materials reported to the laboratory supervisor .....	<input type="checkbox"/>	<input type="checkbox"/>	<input type="checkbox"/>	
Appropriate decontaminant used during spill clean-ups .....	<input type="checkbox"/>	<input type="checkbox"/>	<input type="checkbox"/>	
Work surfaces decontaminated before and after each procedure, daily and after spills .....	<input type="checkbox"/>	<input type="checkbox"/>	<input type="checkbox"/>	
<b>Handling of contaminated waste</b>				
Infectious waste containers properly used ....	<input type="checkbox"/>	<input type="checkbox"/>	<input type="checkbox"/>	
Containers not overfilled .....	<input type="checkbox"/>	<input type="checkbox"/>	<input type="checkbox"/>	
Containers properly labelled and closed .....	<input type="checkbox"/>	<input type="checkbox"/>	<input type="checkbox"/>	
Culture stocks and other regulated waste properly decontaminated before disposal	<input type="checkbox"/>	<input type="checkbox"/>	<input type="checkbox"/>	

CHECKED ITEM (ENTER DATE OF CHECK)	YES	NO	N/A	COMMENTS
Materials decontaminated outside the laboratory transported in closed, durable, leakproof containers according to local rules and regulations .....	<input type="checkbox"/>	<input type="checkbox"/>	<input type="checkbox"/>	
Mixed waste biologically decontaminated prior to disposal as chemical or radiological waste .....	<input type="checkbox"/>	<input type="checkbox"/>	<input type="checkbox"/>	
<b>Personal protection</b>				
Laboratory personnel reminded of appropriate immunizations/tests for agents handled .....	<input type="checkbox"/>	<input type="checkbox"/>	<input type="checkbox"/>	
Appropriate medical services contacted for medical evaluations, surveillance and treatment of occupational exposures .....	<input type="checkbox"/>	<input type="checkbox"/>	<input type="checkbox"/>	
Gloves worn when handling infectious material or contaminated equipment .....	<input type="checkbox"/>	<input type="checkbox"/>	<input type="checkbox"/>	
Face protection provided when working outside the BSC with infectious material .....	<input type="checkbox"/>	<input type="checkbox"/>	<input type="checkbox"/>	
Hands washed after removing gloves, after working with infectious agents, before leaving the laboratory .....	<input type="checkbox"/>	<input type="checkbox"/>	<input type="checkbox"/>	
Antimicrobial agent available for immediate first aid .....	<input type="checkbox"/>	<input type="checkbox"/>	<input type="checkbox"/>	
<b>Practices</b>				
BSC used when potential for creating infectious aerosols/splashes exists .....	<input type="checkbox"/>	<input type="checkbox"/>	<input type="checkbox"/>	
Biosafety manual prepared and adopted ....	<input type="checkbox"/>	<input type="checkbox"/>	<input type="checkbox"/>	
Personnel read, review and follow the instructions on practices and procedures, including safety or operations manual (required for all personnel annually) .....	<input type="checkbox"/>	<input type="checkbox"/>	<input type="checkbox"/>	
Procedures performed so as to minimize aerosols/splashes .....	<input type="checkbox"/>	<input type="checkbox"/>	<input type="checkbox"/>	
Needle-locking syringes/single-use needle-syringe units used with infectious agents .....	<input type="checkbox"/>	<input type="checkbox"/>	<input type="checkbox"/>	
Centrifuge cups and rotors opened only in a BSC .....	<input type="checkbox"/>	<input type="checkbox"/>	<input type="checkbox"/>	
Infectious specimens transported outside a BSC in approved containers following approved transport regulations .....	<input type="checkbox"/>	<input type="checkbox"/>	<input type="checkbox"/>	
<b>Facility</b>				
Hand-washing sink available near laboratory exit .....	<input type="checkbox"/>	<input type="checkbox"/>	<input type="checkbox"/>	

Safety surveyor's signature: . . . . . Date survey completed: . . . . .

**Table 7. Containment laboratory – Biosafety Level 3: laboratory safety survey.**  
 This form is used in conjunction with the Biosafety Level 1 and Biosafety Level 2 laboratory safety survey forms

Location . . . . . Date . . . . .

Person in charge of laboratory . . . . .

CHECKED ITEM (ENTER DATE OF CHECK)	YES	NO	N/A	COMMENTS
<b>Facility</b>				
Laboratory separated from unrestricted traffic flow in building .....	<input type="checkbox"/>	<input type="checkbox"/>	<input type="checkbox"/>	
Access to laboratory through an anteroom with self-closing doors .....	<input type="checkbox"/>	<input type="checkbox"/>	<input type="checkbox"/>	
All penetrations in laboratory sealed or sealable for decontamination .....	<input type="checkbox"/>	<input type="checkbox"/>	<input type="checkbox"/>	
Room exhaust air single-pass and exhausted away from occupied areas ....	<input type="checkbox"/>	<input type="checkbox"/>	<input type="checkbox"/>	
Controlled ventilation system to monitor directional airflow available .....	<input type="checkbox"/>	<input type="checkbox"/>	<input type="checkbox"/>	
<b>Personal protection</b>				
Closed-front gowns worn in laboratory .....	<input type="checkbox"/>	<input type="checkbox"/>	<input type="checkbox"/>	
Protective laboratory clothing worn only in laboratory areas .....	<input type="checkbox"/>	<input type="checkbox"/>	<input type="checkbox"/>	
Hand-washing sink foot, elbow or automatically controlled .....	<input type="checkbox"/>	<input type="checkbox"/>	<input type="checkbox"/>	
<b>Hand protection</b>				
Double gloves worn when handling infectious material, potentially contaminated equipment and work surfaces .....	<input type="checkbox"/>	<input type="checkbox"/>	<input type="checkbox"/>	
<b>Respiratory protection</b>				
Respiratory protection worn by all personnel in the laboratory when aerosols are not safely contained in a BSC .....	<input type="checkbox"/>	<input type="checkbox"/>	<input type="checkbox"/>	
<b>Practices</b>				
Mucous membrane protection provided when working with infectious material outside a BSC .....	<input type="checkbox"/>	<input type="checkbox"/>	<input type="checkbox"/>	
Personnel advised of special hazards associated with the agent(s) .....	<input type="checkbox"/>	<input type="checkbox"/>	<input type="checkbox"/>	
Personnel required to read and follow all instructions on practices and procedures, including safety or operations manual ...	<input type="checkbox"/>	<input type="checkbox"/>	<input type="checkbox"/>	
Personnel receive annual updates/additional training for procedural changes .....	<input type="checkbox"/>	<input type="checkbox"/>	<input type="checkbox"/>	
All contaminated waste autoclaved prior to disposal .....	<input type="checkbox"/>	<input type="checkbox"/>	<input type="checkbox"/>	

Safety surveyor's signature: . . . . . Date survey completed: . . . . .





**PART II**

# Laboratory biosecurity



# 9. Laboratory biosecurity concepts

The *Laboratory biosafety manual* has in the past focused on traditional biosafety guidance for laboratories. The manual emphasizes the use of good microbiological work practices, appropriate containment equipment, proper facility design, operation and maintenance, and administrative considerations to minimize the risk of worker injury or illness. In following these recommendations, the risk to the environment and surrounding community-at-large is also minimized. It has now become necessary to expand this traditional approach to biosafety through the introduction of laboratory biosecurity measures. Global events in the recent past have highlighted the need to protect laboratories and the materials they contain from being intentionally compromised in ways that may harm people, livestock, agriculture or the environment. Before the laboratory biosecurity needs of a facility can be defined, however, it is important to understand the distinction between “laboratory biosafety” and “laboratory biosecurity”.

“Laboratory biosafety” is the term used to describe the containment principles, technologies and practices that are implemented to prevent unintentional exposure to pathogens and toxins, or their accidental release. “Laboratory biosecurity” refers to institutional and personal security measures designed to prevent the loss, theft, misuse, diversion or intentional release of pathogens and toxins.

Effective biosafety practices are the very foundation of laboratory biosecurity activities. Through risk assessments, performed as an integral part of an institution’s biosafety programme, information is gathered regarding the type of organisms available, their physical location, the personnel who require access to them, and the identification of those responsible for them. This information can be used to assess whether an institution possesses biological materials that are attractive to those who may wish to use them improperly. National standards should be developed that recognize and address the ongoing responsibility of countries and institutions to protect specimens, pathogens and toxins from misuse.

A specific laboratory biosecurity programme must be prepared and implemented for each facility according to the requirements of the facility, the type of laboratory work conducted, and the local conditions. Consequently, laboratory biosecurity activities should be representative of the institution’s various needs and should include input from scientific directors, principal investigators, biosafety officers, laboratory

scientific staff, maintenance staff, administrators, information technology staff, and law enforcement agencies and security staff if appropriate.

Laboratory biosecurity measures should be based on a comprehensive programme of accountability for pathogens and toxins that includes an updated inventory with storage location, identification of personnel with access, description of use, documentation of internal and external transfers within and between facilities, and any inactivation and/or disposal of the materials. Likewise, an institutional laboratory biosecurity protocol should be established for identifying, reporting, investigating and remediating breaches in laboratory biosecurity, including discrepancies in inventory results. The involvement and roles and responsibilities of public health and security authorities in the event of a security infraction must be clearly defined.

Laboratory biosecurity training, distinct from laboratory biosafety training, should be provided to all personnel. Such training should help personnel understand the need for protection of such materials and the rationale for the specific biosecurity measures, and should include a review of relevant national standards and institution-specific procedures. Procedures describing the security roles and responsibilities of personnel in the event of a security infraction should also be presented during training.

The professional and ethical suitability for working with dangerous pathogens of all personnel who have regular authorized access to sensitive materials is also central to effective laboratory biosecurity activities.

In summary, security precautions should become a routine part of laboratory work, just as have aseptic techniques and other safe microbiological practices. Laboratory biosecurity measures should not hinder the efficient sharing of reference materials, clinical and epidemiological specimens and related information necessary for clinical or public health investigations. Competent security management should not unduly interfere with the day-to-day activities of scientific personnel or be an impediment to conducting research. Legitimate access to important research and clinical materials must be preserved. Assessment of the suitability of personnel, security-specific training and rigorous adherence to pathogen protection procedures are reasonable means of enhancing laboratory biosecurity. All such efforts must be established and maintained through regular risk and threat assessments, and regular review and updating of procedures. Checks for compliance with these procedures, with clear instructions on roles, responsibilities and remedial actions, should be integral to laboratory biosecurity programmes and national standards for laboratory biosecurity.





**PART III**

# Laboratory equipment



# 10. Biological safety cabinets

Biological safety cabinets (BSCs) are designed to protect the operator, the laboratory environment and work materials from exposure to infectious aerosols and splashes that may be generated when manipulating materials containing infectious agents, such as primary cultures, stocks and diagnostic specimens. Aerosol particles are created by any activity that imparts energy into a liquid or semiliquid material, such as shaking, pouring, stirring or dropping liquid onto a surface or into another liquid. Other laboratory activities, such as streaking agar plates, inoculating cell culture flasks with a pipette, using a multichannel pipette to dispense liquid suspensions of infectious agents into microculture plates, homogenizing and vortexing infectious materials, and centrifugation of infectious liquids, or working with animals, can generate infectious aerosols. Aerosol particles of less than 5  $\mu\text{m}$  in diameter and small droplets of 5–100  $\mu\text{m}$  in diameter are not visible to the naked eye. The laboratory worker is generally not aware that such particles are being generated and may be inhaled or may cross-contaminate work surface materials. BSCs, when properly used, have been shown to be highly effective in reducing laboratory-acquired infections and cross-contaminations of cultures due to aerosol exposures. BSCs also protect the environment.

Over the years the basic design of BSCs has undergone several modifications. A major change was the addition of a high-efficiency particulate air (HEPA) filter to the exhaust system. The HEPA filter traps 99.97% of particles of 0.3  $\mu\text{m}$  in diameter and 99.99% of particles of greater or smaller size. This enables the HEPA filter to effectively trap all known infectious agents and ensure that only microbe-free exhaust air is discharged from the cabinet. A second design modification was to direct HEPA-filtered air over the work surface, providing protection of work surface materials from contamination. This feature is often referred to as product protection. These basic design concepts have led to the evolution of three classes of BSCs. The type of protection provided by each is set out in Table 8.

**Note.** Horizontal and vertical outflow cabinets (“clean-air work stations”) are **not** biological safety cabinets and should not be used as such.

## Class I biological safety cabinet

Figure 6 provides a schematic diagram of a Class I BSC. Room air is drawn in through the front opening at a minimum velocity of 0.38 m/s, it passes over the work surface and is discharged from the cabinet through the exhaust duct. The directional flow of

**Table 8. Selection of a biological safety cabinet (BSC), by type of protection needed**

TYPE OF PROTECTION	BSC SELECTION
Personnel protection, microorganisms in Risk Groups 1–3	Class I, Class II, Class III
Personnel protection, microorganisms in Risk Group 4, glove-box laboratory	Class III
Personnel protection, microorganisms in Risk Group 4, suit laboratory	Class I, Class II
Product protection	Class II, Class III only if laminar flow included
Volatile radionuclide/chemical protection, minute amounts	Class IIB1, Class IIA2 vented to the outside
Volatile radionuclide/chemical protection	Class I, Class IIB2, Class III

air whisks aerosol particles that may be generated on the work surface away from the laboratory worker and into the exhaust duct. The front opening allows the operator’s arms to reach the work surface inside the cabinet while he or she observes the work surface through a glass window. The window can also be fully raised to provide access to the work surface for cleaning or other purposes.

The air from the cabinet is exhausted through a HEPA filter: (a) into the laboratory

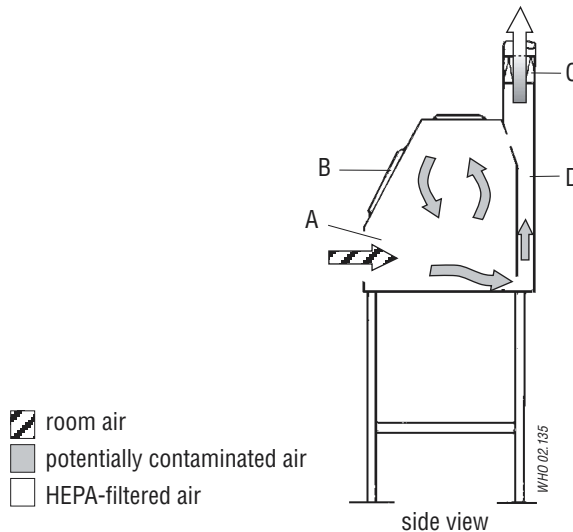

**Figure 6. Schematic diagram of a Class I biological safety cabinet.**  
 A, front opening; B, sash; C, exhaust HEPA filter; D, exhaust plenum.

and then to the outside of the building through the building exhaust; (b) to the outside through the building exhaust; or (c) directly to the outside. The HEPA filter may be located in the exhaust plenum of the BSC or in the building exhaust. Some Class I BSCs are equipped with an integral exhaust fan, whereas others rely on the exhaust fan in the building exhaust system.

The Class I BSC was the first recognized BSC and, because of its simple design, is still in wide use throughout the world. It has the advantage of providing personnel and environmental protection and can also be used for work with radionuclides and volatile toxic chemicals. Because unsterilized room air is drawn over the work surface through the front opening, it is not considered to provide consistently reliable product protection.

### **Class II biological safety cabinets**

As the use of cell and tissue cultures for the propagation of viruses and other purposes grew, it was no longer considered satisfactory for unsterilized room air to pass over the work surface. The Class II BSC was designed not only to provide personnel protection but also to protect work surface materials from contaminated room air. Class II BSCs, of which there are four types (A1, A2, B1 and B2), differ from Class I BSCs by allowing only air from a HEPA-filtered (sterile) supply to flow over the work surface. The Class II BSC can be used for working with infectious agents in Risk Groups 2 and 3. Class II BSCs can be used for working with infectious agents in Risk Group 4 when positive-pressure suits are used.

#### ***Class II type A1 biological safety cabinet***

The Class II type A1 BSC is shown in Figure 7. An internal fan draws room air (supply air) into the cabinet through the front opening and into the front intake grill. The inflow velocity of this air should be at least 0.38 m/s at the face of the front opening. The supply air then passes through a supply HEPA filter before flowing downwards over the work surface. As the air flows downwards it “splits” about 6–18 cm from the work surface, one half of the downwards flowing air passing through the front exhaust grill, and the other half passing through the rear exhaust grill. Any aerosol particles generated at the work surface are immediately captured in this downward airflow and passed through the front or rear exhaust grills, thereby providing the highest level of product protection. The air is then discharged through the rear plenum into the space between the supply and exhaust filters located at the top of the cabinet. Owing to the relative size of these filters, about 70% of the air recirculates through the supply HEPA filter back into the work zone; the remaining 30% passes through the exhaust filter into the room or to the outside.

Air from the Class IIA1 BSC exhaust can be recirculated to the room or discharged to the outside of the building through a thimble connection to a dedicated duct or through the building exhaust system.

Recirculating the exhaust air to the room has the advantage of lowering building

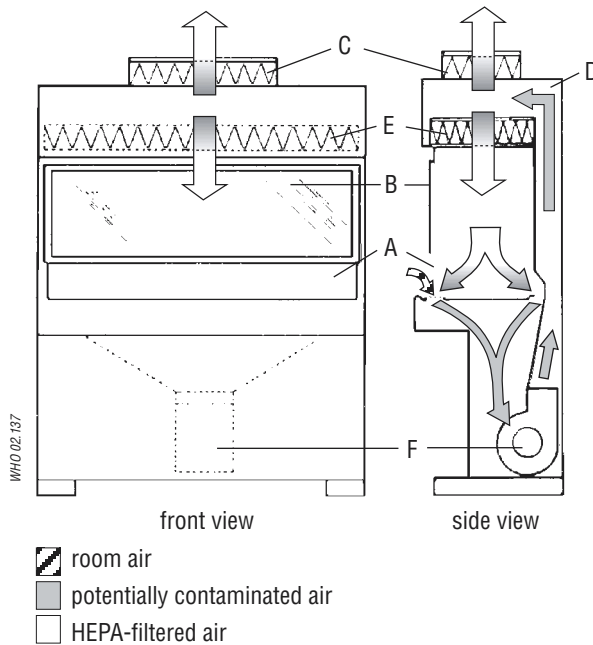

Figure 7. **Schematic representation of a Class IIA1 biological safety cabinet.**

A, front opening; B, sash; C, exhaust HEPA filter; D, rear plenum; E, supply HEPA filter; F, blower.

fuel costs because heated and/or cooled air is not being passed to the outside environment. A connection to a ducted exhaust system also allows some BSCs to be used for work with volatile radionuclides and volatile toxic chemicals (Table 8).

### **Class II type A2 vented to the outside, B1 and B2 biological safety cabinets**

Class IIA2 vented to the outside, IIB1 (Figure 8) and IIB2 BSCs are variations of the type IIA1. Their characteristics, along with those of Class I and Class III BSCs, are indicated in Table 9. Each variation allows the BSC to be used for specialized purposes (see Table 8). These BSCs differ from one another in several aspects: the air intake velocity through the front opening; the amount of air recirculated over the work surface and exhausted from the cabinet; the exhaust system, which determines whether air from the cabinet is exhausted to the room, or to the outside, through a dedicated exhaust system or through the building exhaust; and the pressure arrangements (whether cabinets have biologically contaminated ducts and plenums under negative pressure, or have biological contaminated ducts and plenums surrounded by negative-pressure ducts and plenums).

Complete descriptions of the various Class IIA and IIB BSCs can be obtained from references (7) and (8), and from manufacturers' brochures.

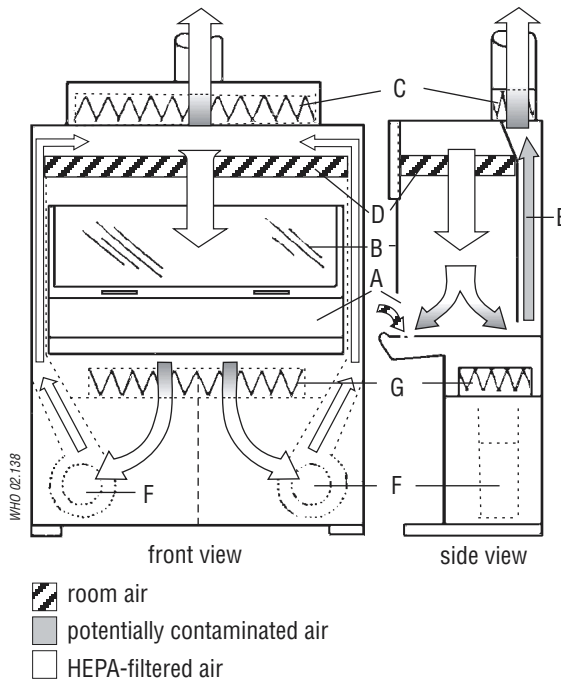

Figure 8. **Schematic diagram of a Class IIB1 biological safety cabinet.** A, front opening; B, sash; C, exhaust HEPA filter; D, supply HEPA filter; E, negative-pressure exhaust plenum; F, blower; G, HEPA filter for supply air. Connection of the cabinet exhaust to the building exhaust air system is required.

Table 9. **Differences between Class I, II and III biological safety cabinets (BSCs)**

BSC	FACE VELOCITY (m/s)	AIRFLOW (%)		EXHAUST SYSTEM
		RECIRCULATED	EXHAUSTED	
Class I <sup>a</sup>	0.36	0	100	Hard duct
Class IIA1	0.38–0.51	70	30	Exhaust to room or thimble connection
Class IIA2 vented to the outside <sup>a</sup>	0.51	70	30	Exhaust to room or thimble connection
Class IIB1 <sup>a</sup>	0.51	30	70	Hard duct
Class IIB2 <sup>a</sup>	0.51	0	100	Hard duct
Class III <sup>a</sup>	NA	0	100	Hard duct

NA, not applicable.

<sup>a</sup> All biologically contaminated ducts are under negative pressure or are surrounded by negative pressure ducts and plenums.

### Class III biological safety cabinet

This type (Figure 9) provides the highest level of personnel protection and is used for Risk Group 4 agents. All penetrations are sealed “gas tight”. Supply air is HEPA-filtered and exhaust air passes through two HEPA filters. Airflow is maintained by a dedicated exhaust system exterior to the cabinet, which keeps the cabinet interior under negative pressure (about 124.5 Pa). Access to the work surface is by means of heavy duty rubber gloves, which are attached to ports in the cabinet. The Class III BSC should have an attached pass-through box that can be sterilized and is equipped with a HEPA-filtered exhaust. The Class III cabinet may be connected to a double-door autoclave used to decontaminate all materials entering or exiting the cabinet. Several glove boxes can be joined together to extend the work surface. Class III BSCs are suitable for work in Biosafety Level 3 and 4 laboratories.

### Biological safety cabinet air connections

A “thimble” or “canopy hood” is designed for use with Class IIA1 and IIA2 vented to the outside BSCs. The thimble fits over the cabinet exhaust housing, sucking the cabinet exhaust air into the building exhaust ducts. A small opening, usually 2.5 cm in diameter,

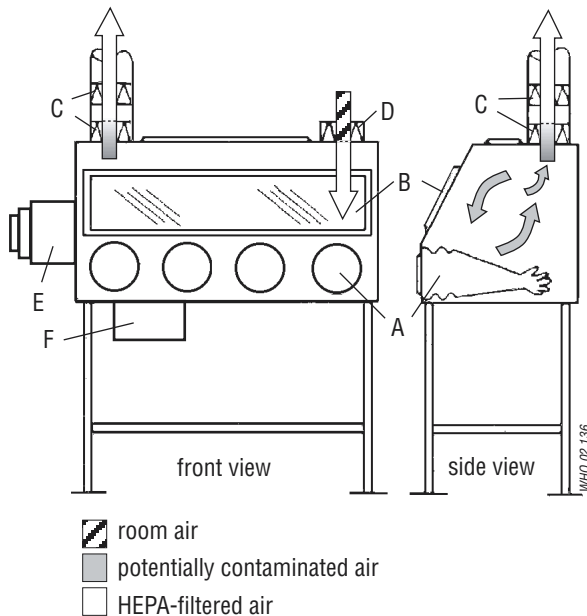

Figure 9. **Schematic representation of a Class III biological safety cabinet (glove box).** A, glove ports for arm-length gloves; B, sash; C, double-exhaust HEPA filters; D, supply HEPA filter; E, double-ended autoclave or pass-through box; F, chemical dunk tank. Connection of the cabinet exhaust to an independent building exhaust air system is required.



is maintained between the thimble and the cabinet exhaust housing. This small opening enables room air to be sucked into the building exhaust system as well. The building exhaust capacity must be sufficient to capture both room air and the cabinet exhaust. The thimble must be removable or be designed to allow for operational testing of the cabinet. Generally, the performance of a thimble-connected BSC is not affected much by fluctuations in the airflow of the building

Class IIB1 and IIB2 BSCs are hard-ducted, i.e. firmly connected without any openings, to the building exhaust system or, preferably, to a dedicated exhaust duct system. The building exhaust system must be precisely matched to the airflow requirements specified by the manufacturer for both volume and static pressure. Certification of hard-duct connected BSCs is more time-consuming than that for BSCs that recirculate air to the room or which are thimble-connected.

### **Selection of a biological safety cabinet**

A BSC should be selected primarily in accordance with the type of protection needed: product protection; personnel protection against Risk Group 1–4 microorganisms; personnel protection against exposure to radionuclides and volatile toxic chemicals; or a combination of these. Table 8 shows which BSCs are recommended for each type of protection.

Volatile or toxic chemicals should not be used in BSCs that recirculate exhaust air to the room, i.e. Class I BSCs that are not ducted to building exhaust systems, or Class IIA1 or Class IIA2 cabinets. Class IIB1 BSCs are acceptable for work with minute amounts of volatile chemicals and radionuclides. A Class IIB2 BSC, also called a total exhaust cabinet, is necessary when significant amounts of radionuclides and volatile chemicals are expected to be used.

### **Using biological safety cabinets in the laboratory**

#### ***Location***

The velocity of air flowing through the front opening into a BSC is about 0.45 m/s. At this velocity the integrity of the directional air inflow is fragile and can be easily disrupted by air currents generated by people walking close to the BSC, open windows, air supply registers, and opening and shutting doors. Ideally, BSCs should be situated in a location remote from traffic and potentially disturbing air currents. Whenever possible a 30-cm clearance should be provided behind and on each side of the cabinet to allow easy access for maintenance. A clearance of 30–35 cm above the cabinet may be required to provide for accurate air velocity measurement across the exhaust filter and for exhaust filter changes.

#### ***Operators***

If BSCs are not used properly, their protective benefits may be greatly diminished. Operators need to be careful to maintain the integrity of the front opening air inflow when moving their arms into and out of cabinets. Arms should be moved in and out

slowly, perpendicular to the front opening. Manipulations of materials within BSCs should be delayed for about 1 min after placing hands and arms inside to allow the cabinet to adjust and to “air sweep” the surface of the hands and arms. The number of movements across the front opening should also be minimized by placing all necessary items into the cabinet before beginning manipulations.

### ***Material placement***

The front intake grill of Class II BSCs must not be blocked with paper, equipment or other items. Materials to be placed inside the cabinet should be surface-decontaminated with 70% alcohol. Work may be performed on disinfectant-soaked absorbent towels to capture splatters and splashes. All materials should be placed as far back in the cabinet, towards the rear edge of the work surface, as practical without blocking the rear grill. Aerosol-generating equipment (e.g. mixers, centrifuges, etc.) should be placed towards the rear of the cabinet. Bulky items, such as biohazard bags, discard pipette trays and suction collection flasks should be placed to one side of the interior of the cabinet. Active work should flow from clean to contaminated areas across the work surface.

The autoclavable biohazard collection bag and pipette collection tray should not be placed outside the cabinet. The frequent in-and-out movement needed to use these containers is disruptive to the integrity of the cabinet’s air barrier, and can compromise both personnel and product protection.

### ***Operation and maintenance***

Most BSCs are designed to permit operation 24 h/day, and investigators find that continuous operation helps to control the levels of dust and particulate materials in the laboratory. Class IIA1 and IIA2 BSCs exhausting to the room or connected by thimble connections to dedicated exhaust ducts can be turned off when not in use. Other types such as IIB1 and IIB2 BSCs, which have hard-duct installations, must have airflow through them at all times to help maintain room air balance. Cabinets should be turned on at least 5 min before beginning work and after completion of work to allow the cabinet to “purge”, i.e. to allow time for contaminated air to be removed from the cabinet environment.

All repairs made on BSCs should be made by a qualified technician. Any malfunction in the operation of the BSC should be reported and repaired before the BSC is used again.

### ***Ultraviolet lights***

Ultraviolet lights are not required in BSCs. If they are used, they must be cleaned weekly to remove any dust and dirt that may block the germicidal effectiveness of the light. Ultraviolet light intensity should be checked when the cabinet is recertified to ensure that light emission is appropriate. Ultraviolet lights must be turned off while the room is occupied, to protect eyes and skin from inadvertent exposure.

### ***Open flames***

Open flames should be avoided in the near microbe-free environment created inside the BSC. They disrupt the airflow patterns and can be dangerous when volatile, flammable substances are also used. To sterilize bacteriological loops, microburners or electric “furnaces” are available and are preferable to open flames.

### ***Spills***

A copy of the laboratory’s protocol for handling spills should be posted, read and understood by everyone who uses the laboratory. When a spill of biohazardous material occurs within a BSC, clean-up should begin immediately, while the cabinet continues to operate. An effective disinfectant should be used and applied in a manner that minimizes the generation of aerosols. All materials that come into contact with the spilled agent should be disinfected and/or autoclaved.

### ***Certification***

The functional operation and integrity of each BSC should be certified to national or international performance standards at the time of installation and regularly thereafter by qualified technicians, according to the manufacturer’s instructions. Evaluation of the effectiveness of cabinet containment should include tests for cabinet integrity, HEPA filter leaks, downflow velocity profile, face velocity, negative pressure/ventilation rate, air-flow smoke pattern, and alarms and interlocks. Optional tests for electrical leaks, lighting intensity, ultraviolet light intensity, noise level and vibration may also be conducted. Special training, skills and equipment are required to perform these tests and it is highly recommended that they are undertaken by a qualified professional.

### ***Cleaning and disinfection***

All items within BSCs, including equipment, should be surface-decontaminated and removed from the cabinet when work is completed, since residual culture media may provide an opportunity for microbial growth.

The interior surfaces of BSCs should be decontaminated before and after each use. The work surfaces and interior walls should be wiped with a disinfectant that will kill any microorganisms that might be found inside the cabinet. At the end of the work day, the final surface decontamination should include a wipe-down of the work surface, the sides, back and interior of the glass. A solution of bleach or 70% alcohol should be used where effective for target organisms. A second wiping with sterile water is needed when a corrosive disinfectant, such as bleach, is used.

It is recommended that the cabinet is left running. If not, it should be run for 5 min in order to purge the atmosphere inside before it is switched off.

### ***Decontamination***

BSCs must be decontaminated before filter changes and before being moved. The most common decontamination method is by fumigation with formaldehyde gas. BSC decontamination should be performed by a qualified professional.

***Personal protective equipment***

Personal protective clothing should be worn whenever using a BSC. Laboratory coats are acceptable for work being performed at Biosafety Levels 1 and 2. A solid front, back-closing laboratory gown provides better protection and should be used at Biosafety Levels 3 and 4 (except for suit laboratories). Gloves should be pulled over the wrists of the gown rather than worn inside. Elasticized sleeves can be worn to protect the investigator's wrists. Masks and safety glasses may be required for some procedures.

***Alarms***

BSCs can be equipped with one of two kinds of alarm. Sash alarms are found only on cabinets with sliding sashes. The alarm signifies that the operator has moved the sash to an improper position. Corrective action for this type of alarm is returning the sash to the proper position. Airflow alarms indicate a disruption in the cabinet's normal airflow pattern. This represents an immediate danger to the operator or product. When an airflow alarm sounds, work should cease immediately and the laboratory supervisor should be notified. Manufacturers' instruction manuals should provide further details. Training in the use of BSCs should cover this aspect.

***Supplementary information***

Selecting the correct type of BSC, installing it, using it properly and annually certifying its operation are complex processes. It is highly recommended that they proceed under the supervision of a well-trained and experienced biosafety professional. The professional should be highly familiar with the relevant literature listed in the References section, and should have been trained on all aspects of BSCs. Operators should receive formal training in the operation and use of BSCs.

For further information see references (5) and (7–16), and Chapter 11.

# 11. Safety equipment

As aerosols are important sources of infection, care should be taken to reduce the extent of their formation and dispersion. Hazardous aerosols can be generated by many laboratory operations, e.g. blending, mixing, grinding, shaking, stirring, sonicating and centrifuging of infectious materials. Even when safe equipment is used, it is best to carry out these operations in an approved biological safety cabinet whenever possible. Biological safety cabinets and their use and testing are discussed in Chapter 10. The use of safety equipment is no assurance of protection unless the operator is trained and uses proper techniques. Equipment should be tested regularly to ensure its continued safe performance.

Table 10 provides a checklist of safety equipment designed to eliminate or reduce certain hazards and briefly outlines the safety features. Further details of much of this equipment are given in subsequent pages. Additional information on its proper use is provided in Chapter 12.

Information on equipment and operations that may create hazards is presented in Annex 4.

## **Negative-pressure flexible-film isolators**

The negative-pressure flexible-film isolator is a self-contained primary containment device that provides maximum protection against hazardous biological materials. It may be mounted on a mobile stand. The workspace is totally enclosed in a transparent polyvinylchloride (PVC) envelope suspended from a steel framework. The isolator is maintained at an internal pressure lower than atmospheric pressure. Inlet air is passed through one HEPA filter and outlet air is passed through two HEPA filters, thus obviating the need to duct exhaust air outside the building. The isolator may be fitted with an incubator, microscope and other laboratory equipment, such as centrifuges, animal cages, heat blocks, etc. Material is introduced and removed from the isolator through supply and sample ports without compromising microbiological security. Manipulations are performed using gloved sleeves incorporating disposable gloves. A manometer is installed to monitor envelope pressure.

Flexible-film isolators are used to manipulate high-risk organisms (Risk Groups 3 or 4) in field work where it is not feasible or appropriate to install or maintain conventional biological safety cabinets.

**Table 10. Biosafety equipment**

EQUIPMENT	HAZARD CORRECTED	SAFETY FEATURES
Biological safety cabinet		
— Class I	Aerosol and spatter	<ul style="list-style-type: none"> <li>• Minimum inward airflow (face velocity) at work access opening. Adequate filtration of exhaust air.</li> </ul>
— Class II	Aerosol and spatter	<ul style="list-style-type: none"> <li>• Does not provide product protection</li> <li>• Minimum inward airflow (face velocity) at work access opening. Adequate filtration of exhaust air</li> </ul>
— Class III	Aerosol and spatter	<ul style="list-style-type: none"> <li>• Provides product protection</li> <li>• Maximum containment</li> <li>• Provides product protection if laminar flow air is included</li> </ul>
Negative pressure flexible-film isolator	Aerosol and spatter	<ul style="list-style-type: none"> <li>• Maximum containment</li> </ul>
Spatter shield	Spatter of chemicals	<ul style="list-style-type: none"> <li>• Forms screen between operator and work</li> </ul>
Pipetting aids	Hazards from pipetting by mouth, e.g. ingestion of pathogens, inhalation of aerosols produced by mouth suction on pipette, blowing out of liquid or dripping from pipette, contamination of suction end of pipette	<ul style="list-style-type: none"> <li>• Ease of use</li> <li>• Controls contamination of suction end of pipette, protecting pipetting aid, user and vacuum line</li> <li>• Can be sterilized</li> <li>• Controls leakage from pipette tip</li> </ul>
Loop microincinerators, disposable loops	Spatter from transfer loops	<ul style="list-style-type: none"> <li>• Shielded in open-ended glass or ceramic tube. Heated by gas or electricity</li> <li>• Disposable, no heating necessary</li> </ul>
Leakproof vessels for collection and transport of infectious materials for sterilization within a facility	Aerosols, spillage and leakage	<ul style="list-style-type: none"> <li>• Leakproof construction with lid or cover</li> <li>• Durable</li> <li>• Autoclavable</li> </ul>
Sharps disposal containers	Puncture wounds	<ul style="list-style-type: none"> <li>• Autoclavable</li> <li>• Robust, puncture-proof</li> </ul>
Transport containers between laboratories, institutions	Release of microorganisms	<ul style="list-style-type: none"> <li>• Robust</li> <li>• Watertight primary and secondary containers to contain spills</li> <li>• Absorbent material to contain spills</li> </ul>

EQUIPMENT	HAZARD CORRECTED	SAFETY FEATURES
Autoclaves, manual or automatic	Infectious material (made safe for disposal or reuse)	<ul style="list-style-type: none"> <li>• Approved design</li> <li>• Effective heat sterilization</li> </ul>
Screw-capped bottles	Aerosols and spillage	<ul style="list-style-type: none"> <li>• Effective containment</li> </ul>
Vacuum line protection	Contamination of laboratory vacuum system with aerosols and overflow fluids	<ul style="list-style-type: none"> <li>• Cartridge-type filter prevents passage of aerosols (particle size 0.45 <math>\mu\text{m}</math>)</li> <li>• Overflow flask contains appropriate disinfectant. Rubber bulb may be used to close off vacuum automatically when storage flask is full</li> <li>• Entire unit autoclavable</li> </ul>

### Pipetting aids

A pipetting aid must always be used for pipetting procedures. Mouth pipetting must be strictly forbidden.

The importance of pipetting aids cannot be overemphasized. The most common hazards associated with pipetting procedures are the result of mouth suction. Oral aspiration and ingestion of hazardous materials have been responsible for many laboratory-associated infections.

Pathogens can also be transferred to the mouth if a contaminated finger is placed on the suction end of a pipette. A lesser known hazard of mouth pipetting is the inhalation of aerosols caused by suction. The cotton plug is not an efficient microbial filter at negative or positive pressure, and particles may be sucked through it. Violent suction may be applied when the plug is tightly packed, resulting in the aspiration of plug, aerosol and even liquid. The ingestion of pathogens is prevented by the use of pipetting aids.

Aerosols can also be generated when a liquid is dropped from a pipette on to a work surface, when cultures are mixed by alternate sucking and blowing, and when the last drop is blown out of a pipette. The inhalation of aerosols unavoidably generated during pipetting operations can be prevented by working in a biological safety cabinet.

Pipetting aids should be selected with care. Their design and use should not create an additional infectious hazard and they should be easy to sterilize and clean. Plugged (aerosol-resistant) pipette tips should be used when manipulating microorganisms and cell cultures.

Pipettes with cracked or chipped suction ends should not be used as they damage the seating seals of pipetting aids and so create a hazard.

### Homogenizers, shakers, blenders and sonicators

Domestic (kitchen) homogenizers are not sealed and release aerosols. Only equipment designed for laboratory use should be used. Their construction minimizes or prevents

such release. Stomachers, which are now available for use with large and small volumes, may also produce aerosols.

Homogenizers used for Risk Group 3 microorganisms should always be loaded and reopened in biological safety cabinets.

Sonicators may release aerosols. They should be operated in biological safety cabinets or covered with shields during use. The shields and outsides of sonicators should be decontaminated after use.

### **Disposable transfer loops**

The advantage of disposable transfer loops is that they do not have to be sterilized and can therefore be used in biological safety cabinets where Bunsen burners and microincinerators would disturb the airflow. These loops should be placed in disinfectant after use and discarded as contaminated waste (see Chapter 3).

### **Microincinerators**

Gas- and electrically-heated microincinerators have borosilicate glass or ceramic shields that minimize the spatter and dispersal of infected material when transfer loops are sterilized. However, microincinerators can disturb the airflow and should therefore be placed towards the back of the work surface in biological safety cabinets.

### **Personal protective equipment and clothing**

Personal protective equipment and clothing may act as a barrier to minimize the risk of exposure to aerosols, splashes and accidental inoculation. The clothing and equipment selected is dependent on the nature of the work performed. Protective clothing should be worn when working in the laboratory. Before leaving the laboratory, protective clothing should be removed, and hands should be washed. Table 11 summarizes some personal protective equipment used in laboratories and the protection afforded.

#### ***Laboratory coats, gowns, coveralls, aprons***

Laboratory coats should preferably be fully buttoned. However, long-sleeved, back-opening gowns or coveralls give better protection than laboratory coats and are preferred in microbiology laboratories and when working at the biological safety cabinet. Aprons may be worn over laboratory coats or gowns where necessary to give further protection against spillage of chemicals or biological materials such as blood or culture fluids. Laundering services should be provided at/near the facility.

Laboratory coats, gowns, coveralls, or aprons should not be worn outside the laboratory areas.

#### ***Goggles, safety spectacles, face shields***

The choice of equipment to protect the eyes and face from splashes and impacting objects will depend on the activity performed. Prescription or plain eye glasses can be



**Table 11. Personal protective equipment**

EQUIPMENT	HAZARD CORRECTED	SAFETY FEATURES
Laboratory coats, gowns, coveralls	Contamination of clothing	<ul style="list-style-type: none"> <li>• Back opening</li> <li>• Cover street clothing</li> </ul>
Plastic aprons	Contamination of clothing	<ul style="list-style-type: none"> <li>• Waterproof</li> </ul>
Footwear	Impact and splash	<ul style="list-style-type: none"> <li>• Closed-toe</li> </ul>
Goggles	Impact and splash	<ul style="list-style-type: none"> <li>• Impact-resistant lenses (must be optically correct or worn over corrective eye glasses)</li> <li>• Side shields</li> </ul>
Safety spectacles	Impact	<ul style="list-style-type: none"> <li>• Impact-resistant lenses (must be optically correct)</li> <li>• Side shields</li> </ul>
Face shields	Impact and splash	<ul style="list-style-type: none"> <li>• Shield entire face</li> <li>• Easily removable in case of accident</li> </ul>
Respirators	Inhalation of aerosols	<ul style="list-style-type: none"> <li>• Designs available include single-use disposable; full-face or half-face air purifying; full-face or hooded powered air purifying (PAPR); and supplied air respirators</li> </ul>
Gloves	Direct contact with microorganisms	<ul style="list-style-type: none"> <li>• Disposable microbiologically approved latex, vinyl or nitrile</li> <li>• Hand protection</li> </ul>
	Cuts	<ul style="list-style-type: none"> <li>• Mesh</li> </ul>

manufactured with special frames that allow lenses to be placed in frame from the front, using shatterproof material either curved or fitted with side shields (safety glasses). Safety spectacles do not provide for adequate splash protection even when side shields are worn with them. Goggles for splash and impact protection should be worn over normal prescription eye glasses and contact lenses (which do not provide protection against biological or chemical hazards). Face shields (visors) are made of shatterproof plastic, fit over the face and are held in place by head straps or caps.

Goggles, safety spectacles, or face shields should not be worn outside the laboratory areas.

### **Respirators**

Respiratory protection may be used when carrying out high-hazard procedures (e.g. cleaning up a spill of infectious material). The choice of respirator will depend on the type of hazard(s). Respirators are available with interchangeable filters for protection against gases, vapours, particulates and microorganisms. It is imperative that the filter is fitted in the correct type of respirator. To achieve optimal protection, respirators

should be individually fitted to the operator's face and tested. Fully self-contained respirators with an integral air supply provide full protection. Advice should be sought from a suitably qualified person, e.g. an occupational hygienist, for selection of the correct respirator. Surgical type masks are designed solely for patient protection and do not provide respiratory protection to workers. Some single-use disposable respirators (ISO 13.340.30) have been designed for protection against exposures to biological agents.

Respirators should not be worn outside the laboratory areas.

### **Gloves**

Contamination of hands may occur when laboratory procedures are performed. Hands are also vulnerable to "sharps" injuries. Disposable microbiologically approved latex, vinyl or nitrile surgical-type gloves are used widely for general laboratory work, and for handling infectious agents and blood and body fluids. Reusable gloves may also be used but attention must be given to their correct washing, removal, cleaning and disinfection.

Gloves should be removed and hands thoroughly washed after handling infectious materials, working in a biological safety cabinet and before leaving the laboratory. Used disposable gloves should be discarded with infected laboratory wastes.

Allergic reactions such as dermatitis and immediate hypersensitivity have been reported in laboratory and other workers wearing latex gloves, particularly those with powder. Alternatives to powdered latex gloves should be available.

Stainless steel mesh gloves should be worn when there is a potential exposure to sharp instruments e.g. during postmortem examinations. Such gloves protect against slicing motion but do not protect against puncture injury.

Gloves should not be worn outside the laboratory areas.

For further information see references (12), (17) and (18).



**PART IV**

# Good microbiological techniques



# 12. Laboratory techniques

Human error, poor laboratory techniques and misuse of equipment cause the majority of laboratory injuries and work-related infections. This chapter provides a compendium of technical methods that are designed to avoid or minimize the most commonly reported problems of this nature.

## **Safe handling of specimens in the laboratory**

Improper collection, transport and handling of specimens in the laboratory carry a risk of infection to the personnel involved.

### ***Specimen containers***

Specimen containers may be of glass or preferably plastic. They should be robust and should not leak when the cap or stopper is correctly applied. No material should remain on the outside of the container. Containers should be correctly labelled to facilitate identification. Specimen request or specification forms should not be wrapped around the containers but placed in separate, preferably waterproof envelopes.

### ***Transport of specimens within the facility***

To avoid accidental leakage or spillage, secondary containers, such as boxes, should be used, fitted with racks so that the specimen containers remain upright. The secondary containers may be of metal or plastic, should be autoclavable or resistant to the action of chemical disinfectants, and the seal should preferably have a gasket. They should be regularly decontaminated.

### ***Receipt of specimens***

Laboratories that receive large numbers of specimens should designate a particular room or area for this purpose.

### ***Opening packages***

Personnel who receive and unpack specimens should be aware of the potential health hazards involved, and should be trained to adopt standard precautions (2), particularly when dealing with broken or leaking containers. Primary specimen containers should be opened in a biological safety cabinet. Disinfectants should be available.

### Use of pipettes and pipetting aids

1. A pipetting aid must always be used. Pipetting by mouth must be prohibited.
2. All pipettes should have cotton plugs to reduce contamination of pipetting devices.
3. Air should never be blown through a liquid containing infectious agents.
4. Infectious materials should not be mixed by alternate suction and expulsion through a pipette.
5. Liquids should not be forcibly expelled from pipettes.
6. Mark-to-mark pipettes are preferable to other types as they do not require expulsion of the last drop.
7. Contaminated pipettes should be completely submerged in a suitable disinfectant contained in an unbreakable container. They should be left in the disinfectant for the appropriate length of time before disposal.
8. A discard container for pipettes should be placed within the biological safety cabinet, not outside it.
9. Syringes fitted with hypodermic needles must not be used for pipetting.
10. Devices for opening septum-capped bottles that allow pipettes to be used and avoid the use of hypodermic needles and syringes should be used.
11. To avoid dispersion of infectious material dropped from a pipette, an absorbent material should be placed on the working surface; this should be disposed of as infectious waste after use.

### Avoiding the dispersal of infectious materials

1. In order to avoid the premature shedding of their loads, microbiological transfer loops should have a diameter of 2–3 mm and be completely closed. The shanks should be not more than 6 cm in length to minimize vibration.
2. The risk of spatter of infectious material in an open Bunsen burner flame should be avoided by using an enclosed electric microincinerator to sterilize transfer loops. Disposable transfer loops, which do not need to be resterilized, are preferable.
3. Care should be taken when drying sputum samples, to avoid creating aerosols.
4. Discarded specimens and cultures for autoclaving and/or disposal should be placed in leakproof containers, e.g. laboratory discard bags. Tops should be secured (e.g. with autoclave tape) prior to disposal into waste containers.
5. Working areas must be decontaminated with a suitable disinfectant at the end of each work period.

For further information see reference (12).

### Use of biological safety cabinets

1. The use and limitations of biological safety cabinets should be explained to all potential users (see Chapter 10), with reference to national standards and relevant literature. Written protocols or safety or operations manuals should be issued to staff. In particular, it must be made clear that the cabinet will not protect the operator from spillage, breakage or poor technique.

2. The cabinet must not be used unless it is working properly.
3. The glass viewing panel must not be opened when the cabinet is in use.
4. Apparatus and materials in the cabinet must be kept to a minimum. Air circulation at the rear plenum must not be blocked.
5. Bunsen burners must not be used in the cabinet. The heat produced will distort the airflow and may damage the filters. An electric microincinerator is permissible but sterile disposable transfer loops are better.
6. All work must be carried out in the middle or rear part of the working surface and be visible through the viewing panel.
7. Traffic behind the operator should be minimized.
8. The operator should not disturb the airflow by repeated removal and reintroduction of his or her arms.
9. Air grills must not be blocked with notes, pipettes or other materials, as this will disrupt the airflow causing potential contamination of the material and exposure of the operator.
10. The surface of the biological safety cabinet should be wiped using an appropriate disinfectant after work is completed and at the end of the day.
11. The cabinet fan should be run for at least 5 min before beginning work and after completion of work in the cabinet.
12. Paperwork should never be placed inside biological safety cabinets.

For further information about biological safety cabinets see Chapter 10.

### **Avoiding ingestion of infectious materials and contact with skin and eyes**

1. Large particles and droplets ( $> 5 \mu\text{m}$  in diameter) released during microbiological manipulations settle rapidly on bench surfaces and on the hands of the operator. Disposable gloves should be worn. Laboratory workers should avoid touching their mouth, eyes and face.
2. Food and drink must not be consumed or stored in the laboratory.
3. No articles should be placed in the mouth – pens, pencils, chewing gum – in the laboratory.
4. Cosmetics should not be applied in the laboratory.
5. The face, eyes and mouth should be shielded or otherwise protected during any operation that may result in the splashing of potentially infectious materials.

### **Avoiding injection of infectious materials**

1. Accidental inoculation resulting from injury with broken or chipped glassware can be avoided through careful practices and procedures. Glassware should be replaced with plastic ware whenever possible.
2. Accidental injection may result from sharps injuries e.g. with hypodermic needles (needle-sticks), glass Pasteur pipettes, or broken glass.
3. Needle-stick injuries can be reduced by: (a) minimizing the use of syringes and needles (e.g. simple devices are available for opening septum-stoppered bottles so

- that pipettes can be used instead of syringes and needles; or (b) using engineered sharp safety devices when syringes and needles are necessary.
4. Needles should never be recapped. Disposable articles should be discarded into puncture-proof/puncture-resistant containers fitted with covers.
  5. Plastic Pasteur pipettes should replace those made of glass.

### **Separation of serum**

1. Only properly trained staff should be employed for this work.
2. Gloves and eye and mucous membrane protection should be worn.
3. Splashes and aerosols can only be avoided or minimized by good laboratory technique. Blood and serum should be pipetted carefully, not poured. Pipetting by mouth must be forbidden.
4. After use, pipettes should be completely submerged in suitable disinfectant. They should remain in the disinfectant for the appropriate time before disposal or washing and sterilization for reuse.
5. Discarded specimen tubes containing blood clots, etc. (with caps replaced) should be placed in suitable leakproof containers for autoclaving and/or incineration.
6. Suitable disinfectants should be available for clean-up of splashes and spillages (see Chapter 14).

### **Use of centrifuges**

1. Satisfactory mechanical performance is a prerequisite of microbiological safety in the use of laboratory centrifuges.
2. Centrifuges should be operated according to the manufacturer's instructions.
3. Centrifuges should be placed at such a level that workers can see into the bowl to place trunnions and buckets correctly.
4. Centrifuge tubes and specimen containers for use in the centrifuge should be made of thick-walled glass or preferably of plastic and should be inspected for defects before use.
5. Tubes and specimen containers should always be securely capped (screw-capped if possible) for centrifugation.
6. The buckets must be loaded, equilibrated, sealed and opened in a biological safety cabinet.
7. Buckets and trunnions should be paired by weight and, with tubes in place, correctly balanced.
8. The amount of space that should be left between the level of the fluid and the rim of the centrifuge tube should be given in manufacturer's instructions.
9. Distilled water or alcohol (propanol, 70%) should be used for balancing empty buckets. Saline or hypochlorite solutions should not be used as they corrode metals.
10. Sealable centrifuge buckets (safety cups) must be used for microorganisms in Risk Groups 3 and 4.
11. When using angle-head centrifuge rotors, care must be taken to ensure that the tube is not overloaded as it might leak.



12. The interior of the centrifuge bowl should be inspected daily for staining or soiling at the level of the rotor. If staining or soiling are evident then the centrifugation protocols should be re-evaluated.
13. Centrifuge rotors and buckets should be inspected daily for signs of corrosion and for hair-line cracks.
14. Buckets, rotors and centrifuge bowls should be decontaminated after each use.
15. After use, buckets should be stored in an inverted position to drain the balancing fluid.
16. Infectious airborne particles may be ejected when centrifuges are used. These particles travel at speeds too high to be retained by the cabinet airflow if the centrifuge is placed in a traditional open-fronted Class I or Class II biological safety cabinet. Enclosing centrifuges in Class III safety cabinets prevents emitted aerosols from dispersing widely. However, good centrifuge technique and securely capped tubes offer adequate protection against infectious aerosols and dispersed particles.

### **Use of homogenizers, shakers, blenders and sonicators**

1. Domestic (kitchen) homogenizers should not be used in laboratories as they may leak or release aerosols. Laboratory blenders and stomachers are safer.
2. Caps and cups or bottles should be in good condition and free from flaws or distortion. Caps should be well-fitting and gaskets should be in good condition.
3. Pressure builds up in the vessel during the operation of homogenizers, shakers and sonicators. Aerosols containing infectious materials may escape from between the cap and the vessel. Plastic, in particular, polytetrafluoroethylene (PTFE) vessels are recommended because glass may break, releasing infectious material and possibly wounding the operator.
4. When in use, homogenizers, shakers and sonicators should be covered by a strong transparent plastic casing. This should be disinfected after use. Where possible, these machines should be operated, under their plastic covers, in a biological safety cabinet.
5. At the end of the operation the containers should be opened in a biological safety cabinet.
6. Hearing protection should be provided for people using sonicators.

### **Use of tissue grinders**

1. Glass grinders should be held in absorbent material in a gloved hand. Plastic (PTFE) grinders are safer.
2. Tissue grinders should be operated and opened in a biological safety cabinet.

### **Care and use of refrigerators and freezers**

1. Refrigerators, deep-freezers and solid carbon dioxide (dry-ice) chests should be defrosted and cleaned periodically, and any ampoules, tubes, etc. that have broken during storage removed. Face protection and heavy duty rubber gloves should be worn during cleaning. After cleaning, the inner surfaces of the cabinet should be disinfected.

2. All containers stored in refrigerators, etc. should be clearly labelled with the scientific name of the contents, the date stored and the name of the individual who stored them. Unlabelled and obsolete materials should be autoclaved and discarded.
3. An inventory must be maintained of the freezer's contents.
4. Flammable solutions must not be stored in a refrigerator unless it is explosion-proof. Notices to this effect should be placed on refrigerator doors.

### **Opening of ampoules containing lyophilized infectious materials**

Care should be taken when ampoules of freeze-dried materials are opened, as the contents may be under reduced pressure and the sudden inrush of air may disperse some of the materials into the atmosphere. Ampoules should always be opened in a biological safety cabinet. The following procedures are recommended for opening ampoules.

1. First decontaminate the outer surface of the ampoule.
2. Make a file mark on the tube near to the middle of the cotton or cellulose plug, if present.
3. Hold the ampoule in alcohol-soaked cotton to protect hands before breaking it at a file scratch.
4. Remove the top gently and treat as contaminated material.
5. If the plug is still above the contents of the ampoule, remove it with sterile forceps.
6. Add liquid for resuspension slowly to the ampoule to avoid frothing.

### **Storage of ampoules containing infectious materials**

Ampoules containing infectious materials should never be immersed in liquid nitrogen because cracked or imperfectly sealed ampoules may break or explode on removal. If very low temperatures are required, ampoules should be stored only in the gaseous phase above the liquid nitrogen. Otherwise, infectious materials should be stored in mechanical deep-freeze cabinets or on dry ice. Laboratory workers should wear eye and hand protection when removing ampoules from cold storage.

The outer surfaces of ampoules stored in these ways should be disinfected when the ampoules are removed from storage.

### **Standard precautions with blood and other body fluids, tissues and excreta**

Standard precautions (which include “universal precautions” (19)) are designed to reduce the risk of transmission of microorganisms from both recognized and unrecognized sources of infection (2).

### **Collection, labelling and transport of specimens**

1. Standard precautions (2) should always be followed; gloves should be worn for all procedures.
2. Blood should be collected from patients and animals by trained staff.
3. For phlebotomies, conventional needle and syringe systems should be replaced by

single-use safety vacuum devices that allow the collection of blood directly into stoppered transport and/or culture tubes, automatically disabling the needle after use.

4. The tubes should be placed in adequate containers for transport to the laboratory (see Chapter 15 for transport requirements) and within the laboratory facility (see section on Transport of specimens within the facility in this chapter). Request forms should be placed in separate waterproof bags or envelopes.
5. Reception staff should **not** open these bags.

### ***Opening specimen tubes and sampling contents***

1. Specimen tubes should be opened in a biological safety cabinet.
2. Gloves must be worn. Eye and mucous membrane protection is also recommended (goggles or face shields).
3. Protective clothing should be supplemented with a plastic apron.
4. The stopper should be grasped through a piece of paper or gauze to prevent splashing.

### ***Glass and “sharps”***

1. Plastics should replace glass wherever possible. Only laboratory grade (borosilicate) glass should be used, and any article that is chipped or cracked should be discarded.
2. Hypodermic needles must not be used as pipettes (see also section on Avoiding injection of infectious materials in this chapter).

### ***Films and smears for microscopy***

Fixing and staining of blood, sputum and faecal samples for microscopy do not necessarily kill all organisms or viruses on the smears. These items should be handled with forceps, stored appropriately, and decontaminated and/or autoclaved before disposal.

### ***Automated equipment (sonicators, vortex mixers)***

1. Equipment should be of the closed type to avoid dispersion of droplets and aerosols.
2. Effluents should be collected in closed vessels for further autoclaving and/or disposal.
3. Equipment should be disinfected at the end of each session, following manufacturers' instructions.

### ***Tissues***

1. Formalin fixatives should be used.
2. Frozen sectioning should be avoided. When necessary, the cryostat should be shielded and the operator should wear a safety face shield. For decontamination, the temperature of the instrument should be raised to at least 20 °C.

### **Decontamination**

Hypochlorites and high-level disinfectants are recommended for decontamination. Freshly prepared hypochlorite solutions should contain available chlorine at 1 g/l for general use and 5 g/l for blood spillages. Glutaraldehyde may be used for decontaminating surfaces (see Chapter 14).

### **Precautions with materials that may contain prions**

Prions (also referred to as “slow viruses”) are associated with the transmissible spongiform encephalopathies (TSEs), notably Creutzfeldt-Jakob disease (CJD; including the new variant form), Gerstmann-Sträussler-Scheinker syndrome, fatal familial insomnia and kuru in humans; scrapie in sheep and goats; bovine spongiform encephalopathy (BSE) in cattle; and other transmissible encephalopathies of deer, elk and mink. Although CJD has been transmitted to humans, there appear to be no proven cases of laboratory-associated infections with any of these agents. Nevertheless, it is prudent to observe certain precautions in the handling of material from infected or potentially infected humans and animals.

The selection of a biosafety level for work with materials associated with TSEs will depend on the nature of the agent and the samples to be studied, and should be undertaken in consultation with national authorities. The highest concentrations of prions are found in central nervous system tissue. Animal studies suggest that it is likely that high concentrations of prions are also found in the spleen, thymus, lymph nodes and lung. Recent studies indicate that prions in lingual and skeletal muscle tissue may also present a potential infection risk (20–23).

As complete inactivation of prions is difficult to achieve, it is important to stress the use of disposable instruments whenever possible, and to use a disposable protective covering for the work surface of the biological safety cabinet.

The main precaution to be taken is to avoid ingestion of contaminated materials or puncture of the laboratory worker’s skin. The following additional precautions should be taken, as the agents are not killed by the normal processes of laboratory disinfection and sterilization.

1. The use of dedicated equipment, i.e. equipment not shared with other laboratories, is highly recommended.
2. Disposable laboratory protective clothing (gowns and aprons) and gloves must be worn (steel mesh gloves between rubber gloves for pathologists).
3. Use of disposable plastic ware, which can be treated and discarded as dry waste, is highly recommended.
4. Tissue processors should not be used because of the problems of disinfection. Jars and beakers (plastic) should be used instead.
5. All manipulations must be conducted in biological safety cabinets.
6. Great care should be exercised to avoid aerosol production, ingestion, and cuts and punctures of the skin.

7. Formalin-fixed tissues should be regarded as still infectious, even after prolonged exposure to formalin.
8. Histological samples containing prions are substantially inactivated after exposure to 96% formic acid for 1 h (24), (25).
9. Bench waste, including disposable gloves, gowns and aprons, should be autoclaved using a porous load steam sterilizer at 134–137 °C for a single cycle of 18 min, or six successive cycles of 3 min each, followed by incineration.
10. Non-disposable instruments, including steel mesh gloves, must be collected for decontamination.
11. Infectious liquid waste contaminated with prions should be treated with sodium hypochlorite containing available chlorine at 20 g/l (2%) (final concentration) for 1 h.
12. Paraformaldehyde vaporization procedures do not diminish prion titres and prions are resistant to ultraviolet irradiation. However, the cabinets must continue to be decontaminated by standard methods (i.e. formaldehyde gas) to inactivate other agents that may be present.
13. Prion-contaminated biological safety cabinets and other surfaces can be decontaminated with sodium hypochlorite containing available chlorine at 20 g/l (2%) for 1 h.
14. High-efficiency particulate air (HEPA) filters should be incinerated at a minimum temperature of 1000 °C after removal. Recommended additional steps prior to incineration include:
  - a. spraying of the exposed face of the filter with lacquer hairspray prior to removal,
  - b. “bagging” of filters during removal, and
  - c. removal of the HEPA filter from the working chamber so that the inaccessible plenum of the cabinet is not contaminated.
15. Instruments should be soaked in sodium hypochlorite containing available chlorine at 20 g/l (2%) for 1 h and then rinsed well in water before autoclaving.
16. Instruments that cannot be autoclaved can be cleaned by repeated wetting with sodium hypochlorite containing available chlorine at 20 g/l (2%) over a 1-h period. Appropriate washing to remove residual sodium hypochlorite is required.

For further information on the handling of unconventional agents see references (12), (26) and (27).

# 13. Contingency plans and emergency procedures

Every laboratory that works with infective microorganisms should institute safety precautions appropriate to the hazard of the organisms and the animals being handled.

A written contingency plan for dealing with laboratory and animal facility accidents is a necessity in any facility that works with or stores Risk Group 3 or 4 microorganisms (containment laboratory – Biosafety Level 3 and maximum containment laboratory – Biosafety Level 4). National and/or local health authorities should be involved in the development of the emergency preparedness plan.

## Contingency plan

The contingency plan should provide operational procedures for:

1. Precautions against natural disasters, e.g. fire, flood, earthquake and explosion
2. Biohazard risk assessment
3. Incident-exposure management and decontamination
4. Emergency evacuation of people and animals from the premises
5. Emergency medical treatment of exposed and injured persons
6. Medical surveillance of exposed persons
7. Clinical management of exposed persons
8. Epidemiological investigation
9. Post-incident continuation of operations.

In the development of this plan the following items should be considered for inclusion:

1. Identification of high-risk organisms
2. Location of high-risk areas, e.g. laboratories, storage areas, animal facilities
3. Identification of at-risk personnel and populations
4. Identification of responsible personnel and their duties, e.g. biosafety officer, safety personnel, local health authority, clinicians, microbiologists, veterinarians, epidemiologists, and fire and police services
5. Lists of treatment and isolation facilities that can receive exposed or infected persons
6. Transport of exposed or infected persons
7. Lists of sources of immune serum, vaccines, drugs, special equipment and supplies
8. Provision of emergency equipment, e.g. protective clothing, disinfectants, chemical and biological spill kits, decontamination equipment and supplies.

## **Emergency procedures for microbiological laboratories**

### ***Puncture wounds, cuts and abrasions***

The affected individual should remove protective clothing, wash the hands and any affected area(s), apply an appropriate skin disinfectant, and seek medical attention as necessary. The cause of the wound and the organisms involved should be reported, and appropriate and complete medical records kept.

### ***Ingestion of potentially infectious material***

Protective clothing should be removed and medical attention sought. Identification of the material ingested and circumstances of the incident should be reported, and appropriate and complete medical records kept.

### ***Potentially infectious aerosol release (outside a biological safety cabinet)***

All persons should immediately vacate the affected area and any exposed persons should be referred for medical advice. The laboratory supervisor and the biosafety officer should be informed at once. No one should enter the room for an appropriate amount of time (e.g. 1 h), to allow aerosols to be carried away and heavier particles to settle. If the laboratory does not have a central air exhaust system, entrance should be delayed (e.g. for 24 h).

Signs should be posted indicating that entry is forbidden. After the appropriate time, decontamination should proceed, supervised by the biosafety officer. Appropriate protective clothing and respiratory protection should be worn.

### ***Broken containers and spilled infectious substances***

Broken containers contaminated with infectious substances and spilled infectious substances should be covered with a cloth or paper towels. Disinfectant should then be poured over these and left for the appropriate amount of time. The cloth or paper towels and the broken material can then be cleared away; glass fragments should be handled with forceps. The contaminated area should then be swabbed with disinfectant. If dustpans are used to clear away the broken material, they should be autoclaved or placed in an effective disinfectant. Cloths, paper towels and swabs used for cleaning up should be placed in a contaminated-waste container. Gloves should be worn for all these procedures.

If laboratory forms or other printed or written matter are contaminated, the information should be copied onto another form and the original discarded into the contaminated-waste container.

### ***Breakage of tubes containing potentially infectious material in centrifuges not having sealable buckets***

If a breakage occurs or is suspected while the machine is running, the motor should be switched off and the machine left closed (e.g. for 30 min) to allow settling. If a breakage is discovered after the machine has stopped, the lid should be replaced immediately

and left closed (e.g. for 30 min). In both instances, the biosafety officer should be informed.

Strong (e.g. thick rubber) gloves, covered if necessary with suitable disposable gloves, should be worn for all subsequent operations. Forceps, or cotton held in the forceps, should be used to retrieve glass debris.

All broken tubes, glass fragments, buckets, trunnions and the rotor should be placed in a noncorrosive disinfectant known to be active against the organisms concerned (see Chapter 14). Unbroken, capped tubes may be placed in disinfectant in a separate container and recovered.

The centrifuge bowl should be swabbed with the same disinfectant, at the appropriate dilution, and then swabbed again, washed with water and dried. All materials used in the clean-up should be treated as infectious waste.

### ***Breakage of tubes inside sealable buckets (safety cups)***

All sealed centrifuge buckets should be loaded and unloaded in a biological safety cabinet. If breakage is suspected within the safety cup, the safety cap should be loosened and the bucket autoclaved. Alternatively, the safety cup may be chemically disinfected.

### ***Fire and natural disasters***

Fire and other services should be involved in the development of emergency preparedness plans. They should be told in advance which rooms contain potentially infectious materials. It is beneficial to arrange for these services to visit the laboratory to become acquainted with its layout and contents.

After a natural disaster, local or national emergency services should be warned of the potential hazards within and/or near laboratory buildings. They should enter only when accompanied by a trained laboratory worker. Infectious materials should be collected in leakproof boxes or strong disposable bags.

Salvage or final disposal should be determined by biosafety staff on the basis of local ordinances.

### ***Emergency services: whom to contact***

The telephone numbers and addresses of the following should be prominently displayed in the facility:

1. The institution or laboratory itself (the address and location may not be known in detail by the caller or the services called)
2. Director of the institution or laboratory
3. Laboratory supervisor
4. Biosafety officer
5. Fire services
6. Hospitals/ambulance services/medical staff (names of individual clinics, departments, and/or medical staff, if possible)



7. Police
8. Medical officer
9. Responsible technician
10. Water, gas and electricity services.

***Emergency equipment***

The following emergency equipment must be available:

1. First-aid kit, including universal and special antidotes
2. Appropriate fire extinguishers, fire blankets

The following are also suggested but may be varied according to local circumstances:

1. Full protective clothing (one-piece coveralls, gloves and head covering – for incidents involving microorganisms in Risk Groups 3 and 4)
2. Full-face respirators with appropriate chemical and particulate filter canisters
3. Room disinfection apparatus, e.g. sprays and formaldehyde vaporizers
4. Stretcher
5. Tools, e.g. hammers, axes, spanners, screwdrivers, ladders, ropes
6. Hazard area demarcation equipment and notices.

For further information see references (12) and (28).

# 14. Disinfection and sterilization

A basic knowledge of disinfection and sterilization is crucial for biosafety in the laboratory. Since heavily soiled items cannot promptly be disinfected or sterilized, it is equally important to understand the fundamentals of cleaning prior to disinfection (precleaning). In this regard, the following general principles apply to all known classes of microbial pathogens.

Specific decontamination requirements will depend on the type of experimental work and the nature of the infectious agent(s) being handled. The generic information given here can be used to develop both standardized and more specific procedures to deal with biohazard(s) involved in a particular laboratory.

Contact times for disinfectants are specific for each material and manufacturer. Therefore, all recommendations for use of disinfectants should follow manufacturers' specifications.

## Definitions

Many different terms are used for disinfection and sterilization. The following are among the more common in biosafety:

**Antimicrobial** – An agent that kills microorganisms or suppresses their growth and multiplication.

**Antiseptic** – A substance that inhibits the growth and development of microorganisms without necessarily killing them. Antiseptics are usually applied to body surfaces.

**Biocide** – A general term for any agent that kills organisms.

**Chemical germicide** – A chemical or a mixture of chemicals used to kill microorganisms.

**Decontamination** – Any process for removing and/or killing microorganisms. The same term is also used for removing or neutralizing hazardous chemicals and radioactive materials.

**Disinfectant** – A chemical or mixture of chemicals used to kill microorganisms, but not necessarily spores. Disinfectants are usually applied to inanimate surfaces or objects.

**Disinfection** – A physical or chemical means of killing microorganisms, but not necessarily spores.

**Microbicide** – A chemical or mixture of chemicals that kills microorganisms. The term is often used in place of “biocide”, “chemical germicide” or “antimicrobial”.

**Sporocide** – A chemical or mixture of chemicals used to kill microorganisms and spores.

**Sterilization** – A process that kills and/or removes all classes of microorganisms and spores.

### **Cleaning laboratory materials**

Cleaning is the removal of dirt, organic matter and stains. Cleaning includes brushing, vacuuming, dry dusting, washing or damp mopping with water containing a soap or detergent. Dirt, soil and organic matter can shield microorganisms and can interfere with the killing action of decontaminants (antiseptics, chemical germicides and disinfectants).

Precleaning is essential to achieve proper disinfection or sterilization. Many germicidal products claim activity only on precleaned items. Precleaning must be carried out with care to avoid exposure to infectious agents.

Materials chemically compatible with the germicides to be applied later must be used. It is quite common to use the same chemical germicide for precleaning and disinfection.

### **Chemical germicides**

Many types of chemicals can be used as disinfectants and/or antiseptics. As there is an ever-increasing number and variety of commercial products, formulations must be carefully selected for specific needs.

The germicidal activity of many chemicals is faster and better at higher temperatures. At the same time, higher temperatures can accelerate their evaporation and also degrade them. Particular care is needed in the use and storage of such chemicals in tropical regions, where their shelf-life may be reduced because of high ambient temperatures.

Many germicides can be harmful to humans or the environment. They should be selected, stored, handled, used and disposed of with care, following manufacturers' instructions. For personal safety, gloves, aprons and eye protection are recommended when preparing dilutions of chemical germicides.

Chemical germicides are generally not required for regular cleaning of floors, walls, equipment and furniture. However, their use may be appropriate in certain cases of outbreak control.

Proper use of chemical germicides will contribute to workplace safety while reducing the risk from infectious agents. As far as possible, the number of germicidal chemicals to be used should be limited for economic reasons, inventory control and to limit environmental pollution.

Commonly used classes of chemical germicides are described below, with generic information on their applications and safety profiles. Unless otherwise indicated, the germicide concentrations are given in weight/volume (w/v). Table 12 summarizes the recommended dilutions of chlorine-releasing compounds.

**Table 12. Recommended dilutions of chlorine-releasing compounds**

	"CLEAN" CONDITIONS <sup>a</sup>	"DIRTY" CONDITIONS <sup>b</sup>
Available chlorine required	0.1% (1 g/l)	0.5% (5 g/l)
Sodium hypochlorite solution (5% available chlorine)	20 ml/l	100 ml/l
Calcium hypochlorite (70% available chlorine)	1.4 g/l	7.0 g/l
Sodium dichloroisocyanurate powder (60% available chlorine)	1.7 g/l	8.5 g/l
Sodium dichloroisocyanurate tablets (1.5 g available chlorine per tablet)	1 tablet per litre	4 tablets per litre
Chloramine (25% available chlorine) <sup>c</sup>	20 g/l	20 g/l

<sup>a</sup> After removal of bulk material.

<sup>b</sup> For flooding, e.g. on blood or before removal of bulk material.

<sup>c</sup> See text.

### Chlorine (sodium hypochlorite)

Chlorine, a fast-acting oxidant, is a widely available and broad-spectrum chemical germicide. It is normally sold as bleach, an aqueous solution of sodium hypochlorite (NaOCl), which can be diluted with water to provide various concentrations of available chlorine.

Chlorine, especially as bleach, is highly alkaline and can be corrosive to metal. Its activity is considerably reduced by organic matter (protein). Storage of stock or working solutions of bleach in open containers, particularly at high temperatures, releases chlorine gas thus weakening their germicidal potential. The frequency with which working solutions of bleach should be changed depends on their starting strength, the type (e.g. with or without a lid) and size of their containers, the frequency and nature of use, and ambient conditions. As a general guide, solutions receiving materials with high levels of organic matter several times a day should be changed at least daily, while those with less frequent use may last for as long as a week.

A general all-purpose laboratory disinfectant should have a concentration of 1 g/l available chlorine. A stronger solution, containing 5 g/l available chlorine, is recommended for dealing with biohazardous spillage and in the presence of large amounts of organic matter. Sodium hypochlorite solutions, as domestic bleach, contain 50 g/l available chlorine and should therefore be diluted 1:50 or 1:10 to obtain final concentrations of 1 g/l and 5 g/l, respectively. Industrial solutions of bleach have a sodium hypochlorite concentration of nearly 120 g/l and must be diluted accordingly to obtain the levels indicated above.

Granules or tablets of calcium hypochlorite (Ca(ClO)<sub>2</sub>) generally contain about 70% available chlorine. Solutions prepared with granules or tablets, containing 1.4 g/l and 7.0 g/l, will then contain 1.0 g/l and 5 g/l available chlorine, respectively.

Bleach is not recommended as an antiseptic, but may be used as a general-purpose

disinfectant and for soaking contaminated metal-free materials. In emergencies, bleach can also be used to disinfect water for drinking, with a final concentration of 1–2 mg/l available chlorine.

Chlorine gas is highly toxic. Bleach must therefore be stored and used in well-ventilated areas only. Also, bleach must not be mixed with acids to prevent the rapid release of chlorine gas. Many by-products of chlorine can be harmful to humans and the environment, so that indiscriminate use of chlorine-based disinfectants, in particular bleach, should be avoided.

### **Sodium dichloroisocyanurate**

Sodium dichloroisocyanurate (NaDCC) in powder form contains 60% available chlorine. Solutions prepared with NaDCC powder at 1.7 g/l and 8.5 g/l will contain 1 g/l or 5 g/l available chlorine, respectively. Tablets of NaDCC generally contain the equivalent of 1.5 g available chlorine per tablet. One or four tablets dissolved in 1 l of water will give approximately the required concentrations of 1 g/l or 5 g/l, respectively. NaDCC as powder or tablets is easy and safe to store. Solid NaDCC can be applied on spills of blood or other biohazardous liquids and left for at least 10 min before removal. Further cleaning of the affected area can then take place.

### **Chloramines**

Chloramines are available as powders containing about 25% available chlorine. Chloramines release chlorine at a slower rate than hypochlorites. Higher initial concentrations are therefore required for efficiencies equivalent to those of hypochlorites. On the other hand, chloramine solutions are not inactivated by organic matter to the same extent as hypochlorite solutions, and concentrations of 20 g/l are recommended for both “clean” and “dirty” situations.

Chloramine solutions are virtually odour-free. However, items soaked in them must be thoroughly rinsed to remove any residue of the bulking agents added to chloramine-T (sodium tosylchloramide) powders.

### **Chlorine dioxide**

Chlorine dioxide ( $\text{ClO}_2$ ) is a strong and fast-acting germicide, disinfectant agent and oxidizer, often reported to be active at concentrations levels lower than those needed by chlorine as bleach. Chlorine dioxide is unstable as a gas and will undergo decomposition into chlorine gas ( $\text{Cl}_2$ ), oxygen gas ( $\text{O}_2$ ), giving off heat. However, chlorine dioxide is soluble in water and stable in an aqueous solution. Chlorine dioxide can be obtained in two ways: (1) on-site generation by mixing of two separate components, hydrochloric acid (HCl) and sodium chlorite ( $\text{NaClO}_2$ ); and (2) ordering its stabilized form, which is then activated on-site when required.

Of the oxidizing biocides, chlorine dioxide is the most selective oxidant. Ozone and chlorine are much more reactive than chlorine dioxide, and they will be consumed by most organic compounds. Chlorine dioxide, however, reacts only with reduced sulfur

compounds, secondary and tertiary amines, and some other highly reduced and reactive organic compounds. A more stable residue can therefore be achieved with chlorine dioxide at much lower doses than when using either chlorine or ozone. Generated properly, chlorine dioxide can be used more effectively than ozone or chlorine in cases of higher organic loading because of its selectivity.

### **Formaldehyde**

Formaldehyde (HCHO) is a gas that kills all microorganisms and spores at temperatures above 20 °C. However, it is not active against prions.

Formaldehyde is relatively slow-acting and needs a relative humidity level of about 70%. It is marketed as the solid polymer, paraformaldehyde, in flakes or tablets, or as formalin, a solution of the gas in water of about 370 g/l (37%), containing methanol (100 ml/l) as a stabilizer. Both formulations are heated to liberate the gas, which is used for decontamination and disinfection of enclosed volumes such as safety cabinets and rooms (see section on Local environmental decontamination in this chapter). Formaldehyde (5% formalin in water) may be used as a liquid disinfectant.

Formaldehyde is a suspected carcinogen. It is a dangerous, irritant gas that has a pungent smell and its fumes can irritate eyes and mucous membranes. It must therefore be stored and used in a fume-hood or well-ventilated area. National chemical safety regulations must be followed.

### **Glutaraldehyde**

Like formaldehyde, glutaraldehyde ( $\text{OHC}(\text{CH}_2)_3\text{CHO}$ ) is also active against vegetative bacteria, spores, fungi and lipid- and nonlipid-containing viruses. It is non-corrosive and faster acting than formaldehyde. However, it takes several hours to kill bacterial spores.

Glutaraldehyde is generally supplied as a solution with a concentration of about 20 g/l (2%) and some products may need to be “activated” (made alkaline) before use by the addition of a bicarbonate compound supplied with the product. The activated solution can be reused for 1–4 weeks depending on the formulation and type and frequency of its use. Dipsticks supplied with some products give only a rough indication of the levels of active glutaraldehyde available in solutions under use. Glutaraldehyde solutions should be discarded if they become turbid.

Glutaraldehyde is toxic and an irritant to skin and mucous membranes, and contact with it must be avoided. It must be used in a fume-hood or in well-ventilated areas. It is not recommended as a spray or solution for the decontamination of environmental surfaces. National chemical safety regulations must be followed.

### **Phenolic compounds**

Phenolic compounds, a broad group of agents, were among the earliest germicides. However, more recent safety concerns restrict their use. They are active against vegetative bacteria and lipid-containing viruses and, when properly formulated, also show

activity against mycobacteria. They are not active against spores and their activity against nonlipid viruses is variable. Many phenolic products are used for the decontamination of environmental surfaces, and some (e.g. triclosan and chloroxylenol) are among the more commonly used antiseptics.

Triclosan is common in products for hand-washing. It is active mainly against vegetative bacteria and safe for skin and mucous membranes. However, in laboratory-based studies, bacteria made resistant to low concentrations of triclosan also show resistance to certain types of antibiotics. The significance of this finding in the field remains unknown.

Some phenolic compounds are sensitive to and may be inactivated by water hardness and therefore must be diluted with distilled or deionized water.

Phenolic compounds are not recommended for use on food contact surfaces and in areas with young children. They may be absorbed by rubber and can also penetrate the skin. National chemical safety regulations must be followed.

### **Quaternary ammonium compounds**

Many types of quaternary ammonium compounds are used as mixtures and often in combination with other germicides, such as alcohols. They have good activity against some vegetative bacteria and lipid-containing viruses. Certain types (e.g. benzalkonium chloride) are used as antiseptics.

The germicidal activity of certain types of quaternary ammonium compounds is considerably reduced by organic matter, water hardness and anionic detergents. Care is therefore needed in selecting agents for precleaning when quaternary ammonium compounds are to be used for disinfection. Potentially harmful bacteria can grow in quaternary ammonium compound solutions. Owing to low biodegradability, these compounds may also accumulate in the environment.

### **Alcohols**

Ethanol (ethyl alcohol,  $C_2H_5OH$ ) and 2-propanol (isopropyl alcohol,  $(CH_3)_2CHOH$ ) have similar disinfectant properties. They are active against vegetative bacteria, fungi and lipid-containing viruses but not against spores. Their action on nonlipid viruses is variable. For highest effectiveness they should be used at concentrations of approximately 70% (v/v) in water: higher or lower concentrations may not be as germicidal. A major advantage of aqueous solutions of alcohols is that they do not leave any residue on treated items.

Mixtures with other agents are more effective than alcohol alone, e.g. 70% (v/v) alcohol with 100 g/l formaldehyde, and alcohol containing 2 g/l available chlorine. A 70% (v/v) aqueous solution of ethanol can be used on skin, work surfaces of laboratory benches and biosafety cabinets, and to soak small pieces of surgical instruments. Since ethanol can dry the skin, it is often mixed with emollients. Alcohol-based hand-rubs are recommended for the decontamination of lightly soiled hands in situations where proper hand-washing is inconvenient or not possible. However, it must be remembered

that ethanol is ineffective against spores and may not kill all types of nonlipid viruses.

Alcohols are volatile and flammable and must not be used near open flames. Working solutions should be stored in proper containers to avoid the evaporation of alcohols. Alcohols may harden rubber and dissolve certain types of glue. Proper inventory and storage of ethanol in the laboratory is very important to avoid its use for purposes other than disinfection. Bottles with alcohol-containing solutions must be clearly labelled to avoid autoclaving.

### **Iodine and iodophors**

The action of these disinfectants is similar to that of chlorine, although they may be slightly less inhibited by organic matter. Iodine can stain fabrics and environmental surfaces and is generally unsuitable for use as a disinfectant. On the other hand, iodophors and tinctures of iodine are good antiseptics. Polyvidone-iodine is a reliable and safe surgical scrub and preoperative skin antiseptic. Antiseptics based on iodine are generally unsuitable for use on medical/dental devices. Iodine should not be used on aluminium or copper.

Iodine can be toxic. Organic iodine-based products must be stored at 4–10 °C to avoid the growth of potentially harmful bacteria in them.

### **Hydrogen peroxide and peracids**

Like chlorine, hydrogen peroxide ( $H_2O_2$ ) and peracids are strong oxidants and can be potent broad-spectrum germicides. They are also safer than chlorine to humans and the environment.

Hydrogen peroxide is supplied either as a ready-to-use 3% solution or as a 30% aqueous solution to be diluted to 5–10 times its volume with sterilized water. However, such 3–6% solutions of hydrogen peroxide alone are relatively slow and limited as germicides. Products now available have other ingredients to stabilize the hydrogen peroxide content, to accelerate its germicidal action and to make it less corrosive.

Hydrogen peroxide can be used for the decontamination of work surfaces of laboratory benches and biosafety cabinets, and stronger solutions may be suitable for disinfecting heat-sensitive medical/dental devices. The use of vaporized hydrogen peroxide or peracetic acid ( $CH_3COOOH$ ) for the decontamination of heat-sensitive medical/surgical devices requires specialized equipment.

Hydrogen peroxide and peracids can be corrosive to metals such as aluminium, copper, brass and zinc, and can also decolorize fabrics, hair, skin and mucous membranes. Articles treated with them must be thoroughly rinsed before contact with eyes and mucous membranes. They should always be stored away from heat and protected from light.

### **Local environmental decontamination**

Decontamination of the laboratory space, its furniture and its equipment requires a combination of liquid and gaseous disinfectants. Surfaces can be decontaminated using



a solution of sodium hypochlorite (NaOCl); a solution containing 1 g/l available chlorine may be suitable for general environmental sanitation, but stronger solutions (5 g/l) are recommended when dealing with high-risk situations. For environmental decontamination, formulated solutions containing 3% hydrogen peroxide ( $H_2O_2$ ) make suitable substitutes for bleach solutions.

Rooms and equipment can be decontaminated by fumigation with formaldehyde gas generated by heating paraformaldehyde or boiling formalin. This is a highly dangerous process that requires specially trained personnel. All openings in the room (i.e. windows, doors, etc.) should be sealed with masking tape or similar before the gas is generated. Fumigation should be conducted at an ambient temperature of at least 21 °C and a relative humidity of 70%. (See also section on Decontamination of biological safety cabinets in this chapter.)

After fumigation the area must be ventilated thoroughly before personnel are allowed to enter. Appropriate respirators must be worn by anyone entering the room before it has been ventilated. Gaseous ammonium bicarbonate can be used to neutralize the formaldehyde.

Fumigation of smaller spaces with hydrogen peroxide vapour is also effective but requires specialized equipment to generate the vapour.

### **Decontamination of biological safety cabinets**

To decontaminate Class I and Class II cabinets, equipment that independently generates, circulates and neutralizes formaldehyde gas is available. Alternatively, the appropriate amount of paraformaldehyde (final concentration of 0.8% paraformaldehyde in air) should be placed in a frying pan on an electric hot plate. Another frying pan, containing 10% more ammonium bicarbonate than paraformaldehyde, on a second hot plate is also placed inside the cabinet. The hot plate leads are plugged in outside the cabinet, so that operation of the pans can be controlled from the outside by plugging and unplugging the hot plates as necessary. If the relative humidity is below 70%, an open container of hot water should also be placed inside the cabinet before the front closure is sealed in place with strong tape (e.g. duct tape). Heavy gauge plastic sheeting is taped over the front opening and exhaust port to make sure that the gas cannot seep into the room. Penetration of the electric leads passing through the front closure must also be sealed with duct tape.

The plate for the paraformaldehyde pan is plugged in. It is unplugged when all the paraformaldehyde has vaporized. The cabinet is left undisturbed for at least 6 h. The plate for the second pan is then plugged in and the ammonium bicarbonate is allowed to vaporize. This plate is then unplugged and the cabinet blower is switched on for two intervals of approximately 2 s each to allow the ammonium bicarbonate gas to circulate. The cabinet should be left undisturbed for 30 min before the front closure (or plastic sheeting) and the exhaust port sheeting are removed. The cabinet surfaces should be wiped down to remove residues before use.

### Hand-washing/hand decontamination

Whenever possible, suitable gloves should be worn when handling biohazardous materials. However, this does not replace the need for regular and proper hand-washing by laboratory personnel. Hands must be washed after handling biohazardous materials and animals, and before leaving the laboratory.

In most situations, thorough washing of hands with ordinary soap and water is sufficient to decontaminate them, but the use of germicidal soaps is recommended in high-risk situations. Hands should be thoroughly lathered with soap, using friction, for at least 10 s, rinsed in clean water and dried using a clean paper or cloth towel (if available, warm-air hand-dryers may be used).

Foot- or elbow-operated faucets are recommended. Where not fitted, a paper/cloth towel should be used to turn off the faucet handles to avoid recontaminating washed hands.

As mentioned above, alcohol-based hand-rubs may be used to decontaminate lightly soiled hands when proper hand-washing is not available.

### Heat disinfection and sterilization

Heat is the most common among the physical agents used for the decontamination of pathogens. “Dry” heat, which is totally non-corrosive, is used to process many items of laboratory ware which can withstand temperatures of 160 °C or higher for 2–4 h. Burning or incineration (see below) is also a form of dry heat. “Moist” heat is most effective when used in the form of autoclaving.

Boiling does not necessarily kill all microorganisms and/or pathogens, but it may be used as the minimum processing for disinfection where other methods (chemical disinfection or decontamination, autoclaving) are not applicable or available.

Sterilized items must be handled and stored such that they remain uncontaminated until used.

### Autoclaving

Saturated steam under pressure (autoclaving) is the most effective and reliable means of sterilizing laboratory materials. For most purposes, the following cycles will ensure sterilization of correctly loaded autoclaves:

1. 3 min holding time at 134 °C
2. 10 min holding time at 126 °C
3. 15 min holding time at 121 °C
4. 25 min holding time at 115 °C.

Examples of different autoclaves include the following.

*Gravity displacement autoclaves.* Figure 10 shows the general construction of a gravity-displacement autoclave. Steam enters the chamber under pressure and displaces the heavier air downwards and through the valve in the chamber drain, fitted with a HEPA filter.

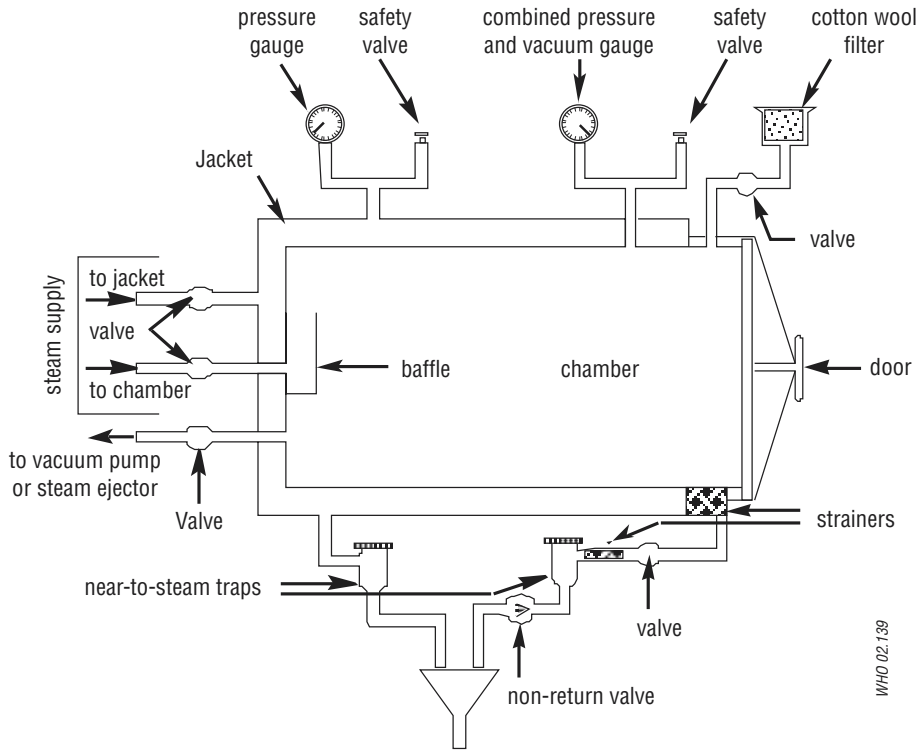

Figure 10. **Gravity displacement autoclave**

*Pre-vacuum autoclaves.* These machines allow the removal of air from the chamber before steam is admitted. The exhaust air is evacuated through a valve fitted with a HEPA filter. At the end of the cycle, the steam is automatically exhausted. These autoclaves can operate at 134 °C and the sterilization cycle can therefore be reduced to 3 min. They are ideal for porous loads, but cannot be used to process liquids because of the vacuum.

*Fuel-heated pressure cooker autoclaves.* These should be used only if a gravity displacement autoclave is not available. They are loaded from the top and heated by gas, electricity or other types of fuels. Steam is generated by heating water in the base of the vessel, and air is displaced upwards through a relief vent. When all the air has been removed, the valve on the relief vent is closed and the heat reduced. The pressure and temperature rise until the safety valve operates at a preset level. This is the start of the holding time. At the end of the cycle the heat is turned off and the temperature allowed to fall to 80 °C or below before the lid is opened.

#### *Loading autoclaves*

Materials should be loosely packed in the chamber for easy steam penetration and air removal. Bags should allow the steam to reach their contents.

### *Precautions in the use of autoclaves*

The following rules can minimize the hazards inherent in operating pressurized vessels.

1. Responsibility for operation and routine care should be assigned to trained individuals.
2. A preventive maintenance programme should include regular inspection of the chamber, door seals and all gauges and controls by qualified personnel.
3. The steam should be saturated and free from chemicals (e.g. corrosion inhibitors) that could contaminate the items being sterilized.
4. All materials to be autoclaved should be in containers that allow ready removal of air and permit good heat penetration; the chamber should be loosely packed so that steam will reach the load evenly.
5. For autoclaves without an interlocking safety device that prevents the door being opened when the chamber is pressurized, the main steam valve should be closed and the temperature allowed to fall below 80 °C before the door is opened.
6. Slow exhaust settings should be used when autoclaving liquids, as they may boil over when removed due to superheating.
7. Operators should wear suitable gloves and visors for protection when opening the autoclave, even when the temperature has fallen below 80 °C.
8. In any routine monitoring of autoclave performance, biological indicators or thermocouples should be placed at the centre of each load. Regular monitoring with thermocouples and recording devices in a “worst case” load is highly desirable to determine proper operating cycles.
9. The drain screen filter of the chamber (if available) should be removed and cleaned daily.
10. Care should be taken to ensure that the relief valves of pressure cooker autoclaves do not become blocked by paper, etc. in the load.

### **Incineration**

Incineration is useful for disposing of animal carcasses as well as anatomical and other laboratory waste, with or without prior decontamination (see Chapter 3). Incineration of infectious materials is an alternative to autoclaving only if the incinerator is under laboratory control.

Proper incineration requires an efficient means of temperature control and a secondary burning chamber. Many incinerators, especially those with a single combustion chamber, are unsatisfactory for dealing with infectious materials, animal carcasses and plastics. Such materials may not be completely destroyed and the effluent from the chimney may pollute the atmosphere with microorganisms, toxic chemicals and smoke. However, there are many satisfactory configurations for combustion chambers. Ideally the temperature in the primary chamber should be at least 800 °C and that in the secondary chamber at least 1000 °C.

Materials for incineration, even with prior decontamination, should be transported

to the incinerator in bags, preferably plastic. Incinerator attendants should receive proper instructions about loading and temperature control. It should also be noted that the efficient operation of an incinerator depends heavily on the right mix of materials in the waste being treated.

There are ongoing concerns regarding the possible negative environmental effects of existing or proposed incinerators, and efforts continue to make incinerators more environmentally friendly and energy-efficient.

### **Disposal**

The disposal of laboratory and medical waste is subject to various regional, national and international regulations, and the latest versions of such relevant documents must be consulted before designing and implementing a programme for handling, transportation and disposal of biohazardous waste. In general, ash from incinerators may be handled as normal domestic waste and removed by local authorities. Autoclaved waste may be disposed of by off-site incineration or in licensed landfill sites (see Chapter 3).

For further information see references (13) and (29–39).

# 15. Introduction to the transport of infectious substances

Transport of infectious and potentially infectious materials is subject to strict national and international regulations. These regulations describe the proper use of packaging materials, as well as other shipping requirements.

Laboratory personnel must ship infectious substances according to applicable transport regulations. Compliance with the rules will:

1. Reduce the likelihood that packages will be damaged and leak, and thereby
2. Reduce the exposures resulting in possible infections
3. Improve the efficiency of package delivery.

## International transport regulations

The regulations for the transport of infectious materials (by any mode of transport) are based upon the United Nations Model *Regulations on the Transport of Dangerous Goods* (40). These recommendations are developed by the United Nations Committee of Experts on the Transport of Dangerous Goods (UNCETDG). To become legally binding, the United Nations Model Regulations have to be introduced into national regulations and international modal regulations by the competent authorities (e.g. the *Technical Instructions for the Safe Transport of Dangerous Goods by Air* (41) of the International Civil Aviation Organization (ICAO) for air transport and the *European Agreement concerning the International Carriage of Dangerous Goods by Road (ADR)* (42).

The International Air Transport Association (IATA) issues *Infectious Substances Shipping Guidelines* (43) every year. IATA guidelines must follow ICAO's *Technical Instructions* as a minimal standard, but may impose additional restrictions. IATA guidelines must be followed if a shipment is carried by members of IATA.

Since the United Nations *Model Regulations on the Transport of Dangerous Goods* is a dynamic set of recommendations subject to biennial amendments, the reader is referred to the latest issuances of national and international modal regulations for applicable regulatory texts.

WHO serves in an advisory capacity to UNCETDG. Major changes to the transport regulations pertaining to the transport of infectious substances were introduced into the 13th edition (2003) of the United Nations *Model Regulations* (40). Guidance on the background to adopted amendments is available from WHO (44).

International modal regulations are not intended to supersede any local or national requirements. However, in situations where national requirements do not exist, international modal regulations should be followed.

It is important to note that international transport of infectious substances is also dependent on and subject to national import/export regulations.

### **The basic triple packaging system**

The triple packaging system, the choice for the transport of infectious and potentially infectious substances, is exemplified in Figure 11. This packaging system consists of three layers: the primary receptacle, the secondary packaging and the outer packaging.

The primary receptacle containing the specimen must be watertight, leakproof and appropriately labelled as to content. The primary receptacle is wrapped in enough absorbent material to absorb all fluid in case of breakage or leakage.

A second watertight, leakproof packaging is used to enclose and protect the primary receptacle(s). Several wrapped primary receptacles may be placed in a single secondary packaging. Volume and/or weight limits for packaged infectious substances are included in certain regulatory texts.

The third layer protects the secondary packaging from physical damage while in transit. Specimen data forms, letters and other types of information that identify or describe the specimen and identify the shipper and receiver, and any other documentation required, must also be provided according to latest regulations.

The United Nations *Model Regulations* prescribe the use of two different triple packaging systems. The basic triple packaging system applies for the transport of a variety of infectious substances; however, high-risk organisms must be shipped according to more stringent requirements. For further details about the use of the different packagings according to the materials to be transported, it is advisable to consult national and/or international modal regulations for applicable regulatory texts.

### **Spill clean-up procedure**

In the event of a spill of infectious or potentially infectious material, the following spill clean-up procedure should be used.

1. Wear gloves and protective clothing, including face and eye protection if indicated.
2. Cover the spill with cloth or paper towels to contain it.
3. Pour an appropriate disinfectant over the paper towels and the immediately surrounding area (generally, 5% bleach solutions are appropriate; but for spills on aircraft, quaternary ammonium disinfectants should be used).
4. Apply disinfectant concentrically beginning at the outer margin of the spill area, working toward the centre.
5. After the appropriate amount of time (e.g. 30 min), clear away the materials. If there is broken glass or other sharps involved, use a dustpan or a piece of stiff cardboard to collect the material and deposit it into a puncture-resistant container for disposal.

**Packing and labelling of Category A infectious substances**

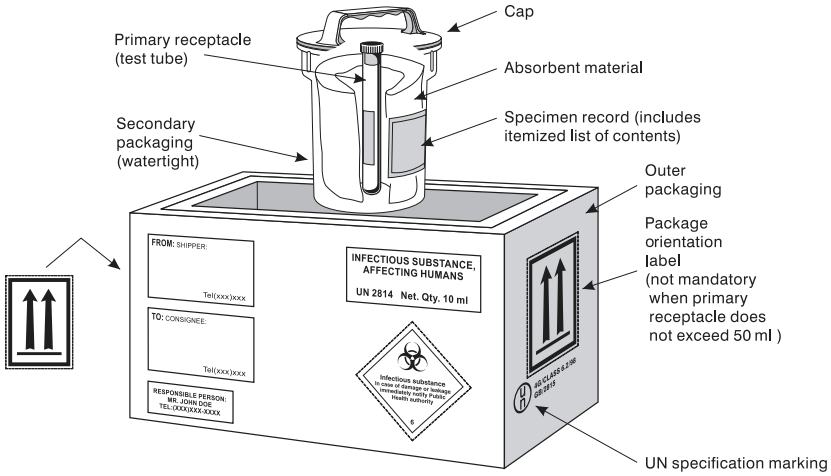

**Packing and labelling of Category B infectious substances**

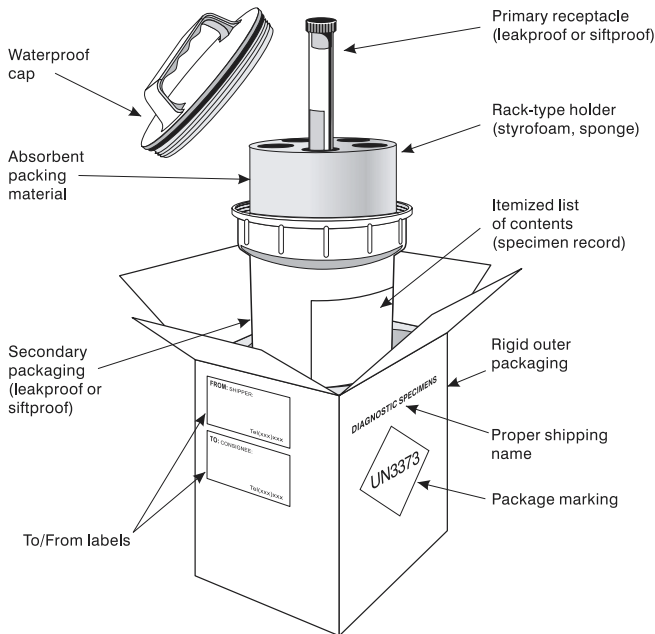

Figure 11. **Examples of triple packaging systems**  
(graphics kindly provided by IATA, Montreal, Canada)



6. Clean and disinfect the area of the spillage (if necessary, repeat steps 2–5).
7. Dispose of contaminated materials into a leakproof, puncture-resistant waste disposal container.
8. After successful disinfection, inform the competent authority that the site has now been decontaminated





**PART V**

# Introduction to biotechnology



# 16. Biosafety and recombinant DNA technology

Recombinant DNA technology involves combining genetic material from different sources thereby creating genetically modified organisms (GMOs) that may have never existed in nature before. Initially there was concern among molecular biologists that such organisms might have unpredictable and undesirable properties that could represent a biohazard if they escaped from the laboratory. This concern became the focus of a scientific conference held in Asilomar, CA, USA, in 1975 (45). At that meeting, safety issues were discussed and the first guidelines for recombinant DNA technology were proposed. The subsequent 25+ years of research experience have demonstrated that genetic engineering may be conducted in a safe manner when an appropriate risk assessment is performed and adequate safety measures are used.

Recombinant DNA technology or genetic engineering was first used to clone DNA segments in bacterial hosts in order to overexpress specific gene products for further studies. Recombinant DNA molecules have also been used to create GMOs such as transgenic and “knock-out” animals and transgenic plants.

Recombinant DNA technology has already had an enormous impact on biology and medicine, and will probably have an even greater influence now that the nucleotide sequence of the entire human genome is available. Tens of thousands of genes of yet unknown functions will be studied using recombinant DNA technology. Gene therapy may become a routine treatment for certain diseases, and new vectors for gene transfer are likely to be devised using genetic engineering techniques. Also, transgenic plants produced by recombinant DNA technology may play an increasingly important role in modern agriculture.

Experiments involving the construction or use of GMOs should be conducted after performing a biosafety risk assessment. The pathogenic properties and any potential hazards associated with such organisms may be novel and not well-characterized. The properties of the donor organism, the nature of the DNA sequences that will be transferred, the properties of the recipient organism, and the properties of the environment should be evaluated. These factors should help determine the biosafety level that is required for the safe handling of the resulting GMO, and identify the biological and physical containment systems that should be used.

### **Biosafety considerations for biological expression systems**

Biological expression systems consist of vectors and host cells. A number of criteria must be satisfied to make them effective and safe to use. An example of such a biological expression system is plasmid pUC18. Frequently used as a cloning vector in combination with *Escherichia coli* K12 cells, the pUC18 plasmid has been entirely sequenced. All genes required for expression in other bacteria have been deleted from its precursor plasmid pBR322. *E. coli* K12 is a non-pathogenic strain that cannot permanently colonize the gut of healthy humans or animals. Routine genetic engineering experiments can safely be performed in *E. coli* K12/pUC18 at Biosafety Level 1, provided the inserted foreign DNA expression products do not require higher biosafety levels.

### **Biosafety considerations for expression vectors**

Higher biosafety levels may be required when:

1. The expression of DNA sequences derived from pathogenic organisms may increase the virulence of the GMO
2. Inserted DNA sequences are not well characterized, e.g. during preparation of genomic DNA libraries from pathogenic microorganisms
3. Gene products have potential pharmacological activity
4. Gene products code for toxins.

### **Viral vectors for gene transfer**

Viral vectors, e.g. adenovirus vectors, are used for the transfer of genes to other cells. Such vectors lack certain virus replication genes and are propagated in cell lines that complement the defect.

Stocks of such vectors may be contaminated with replication-competent viruses, generated by rare spontaneous recombination events in the propagating cell lines, or may derive from insufficient purification. These vectors should be handled at the same biosafety level as the parent adenovirus from which they are derived.

### **Transgenic and “knock-out” animals**

Animals carrying foreign genetic material (transgenic animals) should be handled in containment levels appropriate to the characteristics of the products of the foreign genes. Animals with targeted deletions of specific genes (“knock-out” animals) do not generally present particular biological hazards.

Examples of transgenic animals include animals expressing receptors for viruses normally unable to infect that species. If such animals escaped from the laboratory and transmitted the transgene to the wild animal population, an animal reservoir for that particular virus could theoretically be generated.

This possibility has been discussed for poliovirus and is particularly relevant in the context of poliomyelitis eradication. Transgenic mice expressing the human poliovirus

receptor generated in different laboratories were susceptible to poliovirus infection by various inoculation routes and the resulting disease was clinically and histopathologically similar to human poliomyelitis. However, the mouse model differs from humans in that alimentary tract replication of orally administered poliovirus is either inefficient or does not occur. It is therefore very unlikely that escape of such transgenic mice to the wild would result in the establishment of a new animal reservoir for poliovirus. Nevertheless, this example indicates that, for each new line of transgenic animal, detailed studies should be conducted to determine the routes by which the animals can be infected, the inoculum size required for infection, and the extent of virus shedding by the infected animals. In addition, all measures should be taken to assure strict containment of receptor transgenic mice.

### **Transgenic plants**

Transgenic plants expressing genes that confer tolerance to herbicides or resistance to insects are currently a matter of considerable controversy in many parts of the world. The discussions focus on the food-safety of such plants, and on the long-term ecological consequences of their cultivation.

Transgenic plants expressing genes of animal or human origin are used to develop medicinal and nutritional products. A risk assessment should determine the appropriate biosafety level for the production of these plants.

### **Risk assessments for genetically modified organisms**

Risk assessments for work with GMOs should consider the characteristics of donor and recipient/host organisms.

Examples of characteristics for consideration include the following.

#### ***Hazards arising directly from the inserted gene (donor organism)***

Assessment is necessary in situations where the product of the inserted gene has known biologically or pharmacologically active properties that may give rise to harm, for example:

1. Toxins
2. Cytokines
3. Hormones
4. Gene expression regulators
5. Virulence factors or enhancers
6. Oncogenic gene sequences
7. Antibiotic resistance
8. Allergens.

The consideration of such cases should include an estimation of the level of expression required to achieve biological or pharmacological activity.

***Hazards associated with the recipient/host***

1. Susceptibility of the host
2. Pathogenicity of the host strain, including virulence, infectivity and toxin production
3. Modification of the host range
4. Recipient immune status
5. Consequences of exposure.

***Hazards arising from the alteration of existing pathogenic traits***

Many modifications do not involve genes whose products are inherently harmful, but adverse effects may arise as the result of alteration of existing non-pathogenic or pathogenic traits. Modification of normal genes may alter pathogenicity. In an attempt to identify these potential hazards, the following points may be considered (the list is not exhaustive).

1. Is there an increase in infectivity or pathogenicity?
2. Could any disabling mutation within the recipient be overcome as a result of the insertion of the foreign gene?
3. Does the foreign gene encode a pathogenicity determinant from another organism?
4. If the foreign DNA does include a pathogenicity determinant, is it foreseeable that this gene could contribute to the pathogenicity of the GMO?
5. Is treatment available?
6. Will the susceptibility of the GMO to antibiotics or other forms of therapy be affected as a consequence of the genetic modification?
7. Is eradication of the GMO achievable?

***Further considerations***

The use of whole animals or plants for experimental purposes also requires careful consideration. Investigators must comply with the regulations, restrictions and requirements for the conduct of work with GMOs in host countries and institutions.

Countries may have national authorities that establish guidelines for work with GMOs, and may help scientists classify their work at the appropriate biosafety level. In some cases classification may differ between countries, or countries may decide to classify work at a lower or higher level when new information on a particular vector/host system becomes available.

Risk assessment is a dynamic process that takes into account new developments and the progress of science. The performance of appropriate risk assessments will assure that the benefits of recombinant DNA technology remain available to humankind in the years to come.

For further information see references (17) and (46–48).





**PART VI**

**Chemical, fire and  
electrical safety**



# 17. Hazardous chemicals

Workers in microbiological laboratories are not only exposed to pathogenic microorganisms, but also to chemical hazards. It is important that they have proper knowledge of the toxic effects of these chemicals, the routes of exposure and the hazards that may be associated with handling and storage (see Annex 5). Material safety data sheets or other chemical hazard information are available from chemical manufacturers and/or suppliers. These should be accessible in laboratories where these chemicals are used, e.g. as part of a safety or operations manual.

## Routes of exposure

Exposure to hazardous chemicals may occur by:

1. Inhalation
2. Contact
3. Ingestion
4. Needle-sticks
5. Through broken skin.

## Storage of chemicals

Only amounts of chemicals necessary for daily use should be stored in the laboratory. Bulk stocks should be kept in specially designated rooms or buildings.

**Chemicals should not be stored in alphabetical order.**

## General rules regarding chemical incompatibilities

To avoid fire and/or explosions, substances in the left-hand column of Table 13 should be stored and handled so that they cannot come into contact with the corresponding substances in the right-hand column of the table.

## Toxic effects of chemicals

Some chemicals adversely affect the health of those who handle them or inhale their vapours. Apart from overt poisons, a number of chemicals are known to have various toxic effects. The respiratory system, blood, lungs, liver, kidneys and the gastrointestinal system, as well as other organs and tissues may be adversely affected or seriously damaged. Some chemicals are known to be carcinogenic or teratogenic.

**Table 13. General rules for chemical incompatibilities**

SUBSTANCE CATEGORY	INCOMPATIBLE SUBSTANCES
Alkali metals, e.g. sodium, potassium, caesium and lithium	Carbon dioxide, chlorinated hydrocarbons, water
Halogens	Ammonia, acetylene, hydrocarbons
Acetic acid, hydrogen sulfide, aniline, hydrocarbons, sulfuric acid	Oxidizing agents, e.g. chromic acid, nitric acid, peroxides, permanganates

Some solvent vapours are toxic when inhaled. Apart from the more serious effects noted above, exposure may result in impairments that show no immediate discernible effects on health, but can include lack of coordination, drowsiness and similar symptoms, leading to an increased proneness to accidents.

Prolonged or repeated exposure to the liquid phase of many organic solvents can result in skin damage. This may be due to a defatting effect, but allergic and corrosive symptoms may also arise.

For detailed information on the toxic effects of chemicals see Annex 5.

### Explosive chemicals

Azides, often used in antibacterial solutions, should not be allowed to come into contact with copper or lead (e.g. in waste pipes and plumbing), as they may explode violently when subjected even to a mild impact.

Ethers that have aged and dried to crystals are extremely unstable, and potentially explosive.

Perchloric acid, if allowed to dry on woodwork, brickwork or fabric, will explode and cause a fire on impact.

Picric acid and picrates are detonated by heat and impact.

### Chemical spills

Most manufacturers of laboratory chemicals issue charts describing methods for dealing with spills. Spillage charts and spillage kits are also available commercially. Appropriate charts should be displayed in a prominent position in the laboratory. The following equipment should also be provided:

1. Chemical spill kits
2. Protective clothing, e.g. heavy-duty rubber gloves, overshoes or rubber boots, respirators
3. Scoops and dustpans
4. Forceps for picking up broken glass
5. Mops, cloths and paper towels
6. Buckets

7. Soda ash (sodium carbonate,  $\text{Na}_2\text{CO}_3$ ) or sodium bicarbonate ( $\text{NaHCO}_3$ ) for neutralizing acids and corrosive chemicals
8. Sand (to cover alkali spills)
9. Non-flammable detergent.

The following actions should be taken in the event of a significant chemical spill.

1. Notify the appropriate safety officer.
2. Evacuate non-essential personnel from the area.
3. Attend to persons who may have been contaminated.
4. If the spilled material is flammable, extinguish all open flames, turn off gas in the room and adjacent areas, open windows (if possible), and switch off electrical equipment that may spark.
5. Avoid breathing vapour from spilled material.
6. Establish exhaust ventilation if it is safe to do so.
7. Secure the necessary items (see above) to clean up the spill.

### Compressed and liquefied gases

Information regarding storage of compressed and liquefied gases is given in Table 14.

**Table 14. Storage of compressed and liquefied gases**

CONTAINER	STORAGE INFORMATION
Compressed gas cylinders and liquefied gas containers <sup>a,b</sup>	<ul style="list-style-type: none"> <li>• Should be securely fixed (e.g. chained) to the wall or a solid bench so that they are not inadvertently dislodged.</li> <li>• Must be transported with their caps in place and supported on trolleys.</li> <li>• Should be stored in bulk in an appropriate facility at some distance from the laboratory. This area should be locked and appropriately identified.</li> <li>• Should not be placed near radiators, open flames other heat sources, sparking electrical equipment, or in direct sunlight.</li> </ul>
Small, single-use gas cylinders <sup>a,b</sup>	<ul style="list-style-type: none"> <li>• Must not be incinerated.</li> </ul>

<sup>a</sup> The main high-pressure valve should be turned off when the equipment is not in use and when the room is unoccupied.

<sup>b</sup> Rooms where flammable gas cylinders are used and/or stored should be identified by warning notices on the doors.

For further information see references (1) and (49–51), and Annex 5.

# 18. Additional laboratory hazards

Laboratory personnel may confront hazards posed by forms of energy including fire, electricity, radiation and noise. Basic information about each of these is presented in this chapter.

## Fire hazards

Close cooperation between safety officers and local fire prevention officers is essential. Apart from chemical hazards, the effects of fire on the possible dissemination of infectious material must be considered. This may determine whether it is best to extinguish or contain the fire.

The assistance of local fire prevention officers in the training of laboratory staff in fire prevention, immediate action in case of fire and the use of fire-fighting equipment is desirable.

Fire warnings, instructions and escape routes should be displayed prominently in each room and in corridors and hallways.

Common causes of fires in laboratories are:

1. Electrical circuit overloading
2. Poor electrical maintenance, e.g. poor and perished insulation on cables
3. Excessively long gas tubing or long electrical leads
4. Equipment unnecessarily left switched on
5. Equipment that was not designed for a laboratory environment
6. Open flames
7. Deteriorated gas tubing
8. Improper handling and storage of flammable or explosive materials
9. Improper segregation of incompatible chemicals
10. Sparking equipment near flammable substances and vapours
11. Improper or inadequate ventilation.

Fire-fighting equipment should be placed near room doors and at strategic points in corridors and hallways. This equipment may include hoses, buckets (of water or sand) and a fire extinguisher. Fire extinguishers should be regularly inspected and maintained, and their shelf-life kept up to date. Specific types and uses of fire extinguishers are shown in Table 15.

**Table 15. Types and uses of fire extinguishers**

TYPE	USE FOR	DO NOT USE FOR
Water	Paper, wood, fabric	Electrical fires, flammable liquids, burning metals
Carbon dioxide (CO <sub>2</sub> ) extinguisher gases	Flammable liquids and gases, electrical fires	Alkali metals, paper
Dry powder	Flammable liquids and gases, alkali metals, electrical fires	Reusable equipment and instruments, as residues are very difficult to remove
Foam	Flammable liquids	Electrical fires

For further information see reference (49).

### Electrical hazards

It is essential that all electrical installations and equipment are inspected and tested regularly, including earthing/grounding systems.

Circuit-breakers and earth-fault-interrupters should be installed in appropriate laboratory electrical circuits. Circuit-breakers do not protect people; they are intended to protect wiring from being overloaded with electrical current and hence to prevent fires. Earth-fault-interrupters are intended to protect people from electric shock.

All laboratory electrical equipment should be earthed/grounded, preferably through three-prong plugs.

All laboratory electrical equipment and wiring should conform to national electrical safety standards and codes.

### Noise

The effect of excessive noise is insidious over time. Some types of laboratory equipment, such as certain laser systems, as well as facilities where animals are housed, can produce significant noise exposure to workers. Noise measurement surveys can be conducted to determine the noise hazard. Where warranted by data, engineering controls such as enclosures or barriers around noisy equipment or between noisy areas and other work areas, can be considered. Where noise levels cannot be abated and where laboratory personnel routinely experience excessive exposures, a hearing conservation programme that includes the use of hearing protection while working in hazardous noise and a medical monitoring programme to determine the effect of noise on the workers should be instituted.

### Ionizing radiation

Radiological protection is concerned with protecting humans against the harmful effects of ionizing radiation, which include:

1. Somatic effects, e.g. clinical symptoms observable in exposed individuals. Somatic effects include radiation-induced cancers, e.g. leukaemia and bone, lung and skin cancers, the onset of which may occur many years after irradiation. Less severe somatic effects include minor skin damage, hair loss, blood deficiencies, gastrointestinal damage and cataract formation.
2. Hereditary effects, e.g. symptoms observed in the descendants of exposed individuals. The hereditary effects of radiation exposure to the gonads include chromosome damage or gene mutation. Irradiation of the germ cells in the gonads in high doses can also cause cell death, resulting in impaired fertility in both sexes or menstrual changes in women. Exposure of the developing fetus, particularly in weeks 8–15 of pregnancy, may increase the risk of congenital malformations, mental impairment or radiation-induced cancers in later life.

### **Principles of ionizing radiation protection**

To limit the harmful effects of ionizing radiation, the use of radioisotopes should be controlled and should comply with relevant national standards. Protection from radiation is managed on the basis of four principles:

1. Minimizing the time of radiation exposure
2. Maximizing the distance from the radiation source
3. Shielding the radiation source
4. Substituting the use of radionuclides with non-radiometric techniques.

Protection activities include the following.

1. *Time.* The time of exposure experienced during manipulations of radioactive material can be reduced by:
  - Practising new and unfamiliar techniques without using the radionuclide until the techniques are mastered
  - Working with radionuclides in a deliberate and timely manner without rushing
  - Ensuring that all radioactive sources are returned to storage immediately after use
  - Removing radioactive waste from the laboratory at frequent intervals
  - Spending as little time as possible in the radiation area or laboratory
  - Exercising effective time management and planning of laboratory manipulations involving radioactive material.

The less time spent in a radiation field, the smaller the received personal dose, as described in the equation:

$$\text{Dose} = \text{Dose rate} \times \text{time}$$

2. *Distance.* The dose rate for most  $\gamma$ - and X-radiation varies as the inverse square of the distance from a point source:

$$\text{Dose rate} = \text{Constant} \times 1/\text{Distance}^2$$



Doubling the distance from a radiation source will result in reducing the exposure by one-fourth over the same period of time. Various devices and mechanical aids are used to increase the distance between the operator and the radiation source, e.g. long-handled tongs, forceps, clamps and remote pipetting aids. Note that a small increase in distance can result in significant decrease in the dose rate.

3. *Shielding*. Radiation energy-absorbing or attenuating shields placed between the source and the operator or other occupants of the laboratory will help limit their exposure. The choice and thickness of any shielding material depends on the penetrating ability (type and energy) of the radiation. A barrier of acrylic, wood or lightweight metal, thickness 1.3–1.5 cm, provides shielding against high-energy  $\beta$  particles, whereas high-density lead is needed to shield against high energy  $\gamma$ - and X-radiation.
4. *Substitution*. Radionuclide-based materials should not be used when other techniques are available. If substitution is not possible, then the radionuclide with the least penetrating power or energy should be used.

### **Safe practices for work with radionuclides**

Rules for working with radioactive substances should include considerations in four areas:

1. Radiation area
2. Work-bench area
3. Radioactive waste area
4. Records and emergency response.

Some of the most important rules include the following:

1. *Radiation area*
  - Use radioactive substances only in dedicated areas.
  - Allow the presence of essential staff only.
  - Use personal protective equipment, including laboratory coats, safety spectacles and disposable gloves.
  - Monitor personal radiation exposures.

Laboratories where radionuclides are used should be designed to simplify containment, cleaning and decontamination. The radionuclide work area should be located in a small room adjoining the main laboratory, or in a dedicated area within the laboratory away from other activities. Signs displaying the international radiation hazard symbol should be posted at the entrance to the radiation area (Figure 12).

2. *Work-bench area*
  - Use spill trays lined with disposable absorbent materials.
  - Limit radionuclide quantities.
  - Shield radiation sources in the radiation, work bench and radioactive waste areas.

Figure 12. *International radiation hazard symbol*



- Mark radiation containers with the radiation symbol, including radionuclide identity, activity and assay date.
- Use radiation meters to monitor working areas, protective clothing and hands after completion of work.
- Use appropriately shielded transport containers.

3. *Radioactive waste area*

- Remove radioactive waste frequently from the working area.
- Maintain accurate records of use and disposal of radioactive materials.
- Screen dosimetry records for materials exceeding the dose limits.
- Establish and regularly exercise emergency response plans.
- In emergencies, assist injured persons first.
- Clean contaminated areas thoroughly.
- Request assistance from the safety office, if available.
- Write and keep incident reports.



**PART VII**

**Safety organization  
and training**



# 19. The biosafety officer and biosafety committee

It is essential that each laboratory organization has a comprehensive safety policy, a safety manual, and supporting programmes for their implementation. The responsibility for this normally rests with the director or head of the institute or laboratory, who may delegate certain duties to a biosafety officer or other appropriate personnel.

Laboratory safety is also the responsibility of all supervisors and laboratory employees, and individual workers are responsible for their own safety and that of their colleagues. Employees are expected to perform their work safely and should report any unsafe acts, conditions or incidents to their supervisor. Periodic safety audits by internal or external personnel are desirable.

## **Biosafety officer**

Wherever possible a biosafety officer should be appointed to ensure that biosafety policies and programmes are followed consistently throughout the laboratory. The biosafety officer executes these duties on behalf of the head of the institute or laboratory. In small units, the biosafety officer may be a microbiologist or a member of the technical staff, who may perform these duties on a defined part-time basis. Whatever the degree of involvement in biosafety, the person designated should possess the professional competence necessary to suggest, review and approve specific activities that follow appropriate biocontainment and biosafety procedures. The biosafety officer should apply relevant national and international rules, regulations and guidelines, as well as assist the laboratory in developing standard operating procedures. The person appointed must have a technical background in microbiology, biochemistry and basic physical and biological sciences. Knowledge of laboratory and clinical practices and safety, including containment equipment, and engineering principles relevant to the design, operation and maintenance of facilities is highly desirable. The biosafety officer should also be able to communicate effectively with administrative, technical and support personnel.

The activities of the biosafety officer should include the following:

1. Biosafety, biosecurity and technical compliance consultations.
2. Periodic internal biosafety audits on technical methods, procedures and protocols, biological agents, materials and equipment.

3. Discussions of violation of biosafety protocols or procedures with the appropriate persons.
4. Verification that all staff have received appropriate biosafety training.
5. Provision of continuing education in biosafety.
6. Investigation of incidents involving the possible escape of potentially infectious or toxic material, and reporting of findings and recommendations to the laboratory director and biosafety committee.
7. Coordination with medical staff regarding possible laboratory-acquired infections.
8. Ensuring appropriate decontamination following spills or other incidents involving infectious material(s).
9. Ensuring proper waste management.
10. Ensuring appropriate decontamination of any apparatus prior to repair or servicing.
11. Maintaining awareness of community attitudes regarding health and environmental considerations.
12. Establishment of appropriate procedures for import/export of pathogenic material to/from the laboratory, according to national regulations.
13. Reviewing the biosafety aspects of all plans, protocols and operating procedures for research work involving infectious agents prior to the implementation of these activities.
14. Institution of a system to deal with emergencies.

### **Biosafety committee**

A biosafety committee should be constituted to develop institutional biosafety policies and codes of practice. The biosafety committee should also review research protocols for work involving infectious agents, animal use, recombinant DNA and genetically modified materials. Other functions of the committee may include risk assessments, formulation of new safety policies and arbitration in disputes over safety matters.

The membership of the biosafety committee should reflect the diverse occupational areas of the organization as well as its scientific expertise. The composition of a basic biosafety committee may include:

1. Biosafety officer(s)
2. Scientists
3. Medical personnel
4. Veterinarian(s) (if work with animals is conducted)
5. Representatives of technical staff
6. Representatives of laboratory management.

The biosafety committee should seek advice from different departmental and specialist safety officers (e.g. with expertise in radiation protection, industrial safety, fire prevention, etc.) and may at times require assistance from independent experts in various associated fields, local authorities and national regulatory bodies. Community members may also be helpful if there is a particularly contentious or sensitive protocol under discussion.

## 20. Safety for support staff

The safe and optimum operation of a laboratory is dependent to a great extent on the support staff, and it is essential that such personnel are given appropriate safety training.

### **Engineering and building maintenance services**

Skilled engineers and craftsmen who maintain and repair the structure, facilities and equipment, should have some knowledge of the nature of the work of the laboratory, and of safety regulations and procedures.

Testing of equipment after servicing, e.g. testing the efficiency of biological safety cabinets after new filters have been fitted, may be carried out by or under supervision of the biosafety officer.

Laboratories or institutions that do not have internal engineering and maintenance services should establish good relationships with local service providers to familiarize them with the equipment and work of the laboratory.

Engineering and maintenance staff should only enter Biosafety Level 3 or Biosafety Level 4 laboratories with clearance and supervision by the biosafety officer and/or the laboratory supervisor.

### **Cleaning (domestic) services**

Biosafety Level 3 and Biosafety Level 4 laboratories should be cleaned by the laboratory staff. Cleaning personnel should only enter Biosafety Level 3 or Biosafety Level 4 laboratories with clearance and supervision by the biosafety officer and/or the laboratory supervisor.

# 21. Training programmes

A continuous, on-the-job safety training programme is essential to maintain safety awareness among laboratory and support staff. Laboratory supervisors, with the assistance of the biosafety officer and other resource persons, play the key role in staff training. The effectiveness of biosafety training, indeed all safety and health training, depends on management commitment, motivational factors, adequate initial job training, good communications, and ultimately the organization's goals and objectives. The following are critical elements for an effective biosafety training programme.

1. **Needs assessment.** This process includes defining the tasks involved, the order of importance (in terms of frequency, criticality, complexity) and details of the steps necessary to accomplish them.
2. **Establishing training objectives.** These are observable behaviours that the trainee is expected to demonstrate, on the job, after the training. Objectives may acknowledge the conditions under which certain activities or behaviours are performed and the required level of proficiency.
3. **Specifying training content and media.** Content is the knowledge or skill that the trainee must master to be able to meet the behavioural objectives. Those individuals who know the job and its demands best usually define the content of the biosafety training programme. Other approaches used may focus on the products of problem-solving exercises or the design of learning measures to correct mistakes people have made in using a skill. It is not clear that one teaching method (lectures, televised instruction, computer-aided instruction, interactive video, etc.) is superior to another. Much depends on specific training needs, the make-up of the trainee group, etc.
4. **Accounting for individual learning differences.** Effective training must take into account the characteristics or attributes of the trainees. Individuals and groups may differ in aptitude, literacy, culture, spoken language and pre-training skill levels. How the training programme is viewed by trainees in terms of improving their job performance or personal safety may dictate the approach used. Some individuals are more visual or "hands-on" learners; others learn well from written materials. Any special needs of employees must also be addressed, such as course adaptation for those with hearing impairments. In addition to taking account of these elements, it is recommended that the developers of any safety training programme become acquainted with the principles of adult learning.



5. ***Specifying learning conditions.*** The instructional event (e.g. training course, videotape, written materials, etc.) should not conflict with, inhibit or be unrelated to mastery of the skill or topic being taught. For example, if the intent of the instruction is to develop capabilities in problem-solving techniques, the instructional approach should stress thinking/reasoning approaches rather than rote memorization. The instruction provided should require productive behaviour and/or appropriate feedback (positive/accurate/credible). In addition, instructional events that provide opportunities for practice under conditions similar to that of the job will enhance the transfer of the skill to the actual job.
6. ***Training evaluation.*** This provides information that helps to determine whether the instruction has had the intended effect. Training evaluations generally take four forms:
- measuring the trainees' reaction to the instruction provided
  - measuring the trainees' recollection and/or performance
  - assessing behavioural change on the job
  - measuring tangible results in terms of the organization's objectives or goals.
- The most complete evaluation of a training effort involves assessments for each of the four areas. The least efficient method of evaluation is to consider only the trainees' reactions to the instruction as this may bear little relationship to the extent of actual learning. It should not be used as the sole measurement of training effectiveness.
7. ***Training revision.*** Training evaluations rarely indicate that a training programme is a complete success or failure because multiple criteria are used to measure results. Usually the data indicate a better understanding, retention or application of some parts of the course material as compared with others. Variation or gaps in knowledge or the desired competencies resulting from the training effort may reflect the need to consider more training time, alternative instructional techniques or more capable instructors.

WHO provides various tools for microbiological safety training.





**PART VIII**

# Safety checklist



# 22. Safety checklist

This checklist is intended to assist in assessments of microbiological laboratory safety and security status of biomedical laboratories.

## Laboratory premises

1. Have guidelines for commissioning and certification been considered for facility construction or post-construction evaluations?
2. Do the premises meet national and local building requirements, including those relating to natural disaster precautions if necessary?
3. Are the premises generally uncluttered and free from obstructions?
4. Are the premises clean?
5. Are there any structural defects in floors?
6. Are floors and stairs uniform and slip-resistant?
7. Is the working space adequate for safe operation?
8. Are the circulation spaces and corridors adequate for the movement of people and large equipment?
9. Are the benches, furniture and fittings in good condition?
10. Are bench surfaces resistant to solvents and corrosive chemicals?
11. Is there a hand-washing sink in each laboratory room?
12. Are the premises constructed and maintained to prevent entry and harbourage of rodents and arthropods?
13. Are all exposed steam and hot water pipes insulated or guarded to protect personnel?
14. Is an independent power support unit provided in case of power breakdown?
15. Can access to laboratory areas be restricted to authorized personnel?
16. Has a risk assessment been performed to ensure that appropriate equipment and facilities are available to support the work being considered?

## Storage facilities

1. Are storage facilities, shelves, etc. arranged so that stores are secure against sliding, collapse or falls?
2. Are storage facilities kept free from accumulations of rubbish, unwanted materials and objects that present hazards from tripping, fire, explosion and harbourage of pests?
3. Are freezers and storage areas lockable?

### **Sanitation and staff facilities**

1. Are the premises maintained in a clean, orderly and sanitary condition?
2. Is drinking-water available?
3. Are clean and adequate toilet (WC) and washing facilities provided separately for male and female staff?
4. Are hot and cold water, soap and towels provided?
5. Are separate changing rooms provided for male and female staff?
6. Is there accommodation (e.g. lockers) for street clothing for individual members of the staff?
7. Is there a staff room for lunch, etc.?
8. Are noise levels acceptable?
9. Is there an adequate organization for the collection and disposal of general household rubbish?

### **Heating and ventilation**

1. Is there a comfortable working temperature?
2. Are blinds fitted to windows that are exposed to full sunlight?
3. Is the ventilation adequate, e.g. at least six changes of air per hour, especially in rooms that have mechanical ventilation?
4. Are there HEPA filters in the ventilation system?
5. Does mechanical ventilation compromise airflows in and around biological safety cabinets and fume cupboards?

### **Lighting**

1. Is the general illumination adequate (e.g. 300–400 lx)?
2. Is task (local) lighting provided at work benches?
3. Are all areas well-lit, with no dark or ill-lit corners in rooms and corridors?
4. Are fluorescent lights parallel to the benches?
5. Are fluorescent lights colour-balanced?

### **Services**

1. Is each laboratory room provided with enough sinks, water, electricity and gas outlets for safe working?
2. Is there an adequate inspection and maintenance programme for fuses, lights, cables, pipes, etc.?
3. Are faults corrected within a reasonable time?
4. Are internal engineering and maintenance services available, with skilled engineers and craftsmen who also have some knowledge of the nature of the work of the laboratory?
5. Is the access of engineering and maintenance personnel to various laboratory areas controlled and documented?

6. If no internal engineering and maintenance services are available, have local engineers and builders been contacted and familiarized with the equipment and work of the laboratory?
7. Are cleaning services available?
8. Is the access of cleaning personnel to various laboratory areas controlled and documented?
9. Are information technology services available and secured?

### **Laboratory biosecurity**

1. Has a qualitative risk assessment been performed to define risks that a security system should protect against?
2. Have acceptable risks and incidence response planning parameters been defined?
3. Is the whole building securely locked when unoccupied?
4. Are doors and windows break-proof?
5. Are rooms containing hazardous materials and expensive equipment locked when unoccupied?
6. Is access to such rooms, equipment and materials appropriately controlled and documented?

### **Fire prevention and fire protection**

1. Is there a fire alarm system?
2. Are the fire doors in good order?
3. Is the fire detection system in good working order and regularly tested?
4. Are fire alarm stations accessible?
5. Are all exits marked by proper, illuminated signs?
6. Is access to exits marked where the routes to them are not immediately visible?
7. Are all exits unobstructed by decorations, furniture and equipment, and unlocked when the building is occupied?
8. Is access to exits arranged so that it is not necessary to pass through a high-hazard area to escape?
9. Do all exits lead to an open space?
10. Are corridors, aisles and circulation areas clear and unobstructed for movement of staff and fire-fighting equipment?
11. Is all fire-fighting equipment and apparatus easily identified by an appropriate colour code?
12. Are portable fire extinguishers maintained fully charged and in working order, and kept in designated places at all times?
13. Are laboratory rooms with potential fire hazards equipped with appropriate extinguishers and/or fire blankets for emergency use?
14. If flammable liquids and gases are used in any room, is the mechanical ventilation sufficient to remove vapours before they reach a hazardous concentration?
15. Are personnel trained to respond to fire emergencies?

### **Flammable liquid storage**

1. Is the storage facility for bulk flammable liquids separated from the main building?
2. Is it clearly labelled as a fire-risk area?
3. Does it have a gravity or mechanical exhaust ventilation system that is separate from the main building system?
4. Are the switches for lighting sealed or placed outside the building?
5. Are the light fittings inside sealed to protect against ignition of vapours by sparking?
6. Are flammable liquids stored in proper, ventilated containers that are made of non-combustible materials?
7. Are the contents of all containers correctly described on the labels?
8. Are appropriate fire extinguishers and/or fire blankets placed outside but near to the flammable liquid store?
9. Are “No smoking” signs clearly displayed inside and outside the flammable liquid store?
10. Are only minimum amounts of flammable substances stored in laboratory rooms?
11. Are they stored in properly constructed flammable storage cabinets?
12. Are these cabinets adequately labelled with “Flammable liquid – Fire hazard” signs?
13. Are personnel trained to properly use and transport flammable liquids?

### **Compressed and liquefied gases**

1. Is each portable gas container legibly marked with its contents and correctly colour-coded?
2. Are compressed-gas cylinders and their high-pressure and reduction valves regularly inspected?
3. Are reduction valves regularly maintained?
4. Is a pressure-relief device connected when a cylinder is in use?
5. Are protection caps in place when cylinders are not in use or are being transported?
6. Are all compressed gas cylinders secured so that they cannot fall, especially in the event of natural disaster?
7. Are cylinders and liquid petroleum gas tanks kept away from sources of heat?
8. Are personnel trained to properly use and transport compressed and liquefied gases?

### **Electrical hazards**

1. Are all new electrical installations and all replacements, modifications or repairs made and maintained in accordance with a national electrical safety code?
2. Does the interior wiring have an earthed/grounded conductor (i.e. a three-wire system)?
3. Are circuit-breakers and earth-fault interrupters fitted to all laboratory circuits?
4. Do all electrical appliances have testing laboratory approval?
5. Are the flexible connecting cables of all equipment as short as practicable, in good condition, and not frayed, damaged or spliced?
6. Is each electric socket outlet used for only one appliance (no adapters to be used)?



### **Personal protection**

1. Is protective clothing of approved design and fabric provided for all staff for normal work, e.g. gowns, coveralls, aprons, gloves?
2. Is additional protective clothing provided for work with hazardous chemicals and radioactive and carcinogenic substances, e.g. rubber aprons and gloves for chemicals and for dealing with spillages; heat-resistant gloves for unloading autoclaves and ovens?
3. Are safety glasses, goggles and shields (visors) provided?
4. Are there eye-wash stations?
5. Are there emergency showers (drench facilities)?
6. Is radiation protection in accordance with national and international standards, including provision of dosimeters?
7. Are respirators available, regularly cleaned, disinfected, inspected and stored in a clean and sanitary condition?
8. Are appropriate filters provided for the correct types of respirators, e.g. HEPA filters for microorganisms, appropriate filters for gases or particulates?
9. Are respirators fit-tested?

### **Health and safety of staff**

1. Is there an occupational health service?
2. Are first-aid boxes provided at strategic locations?
3. Are qualified first-aiders available?
4. Are such first-aiders trained to deal with emergencies peculiar to the laboratory, e.g. contact with corrosive chemicals, accidental ingestion of poisons and infectious materials?
5. Are non-laboratory workers, e.g. domestic and clerical staff, instructed on the potential hazards of the laboratory and the material it handles?
6. Are notices prominently posted giving clear information about the location of first-aiders, telephone numbers of emergency services, etc.?
7. Are women of childbearing age warned of the consequences of work with certain microorganisms, carcinogens, mutagens and teratogens?
8. Are women of childbearing age told that if they are, or suspect that they are, pregnant they should inform the appropriate member of the medical/scientific staff so that alternative working arrangements may be made for them if necessary?
9. Is there an immunization programme relevant to the work of the laboratory?
10. Are skin tests and/or radiological facilities available for staff who work with tuberculous materials or other materials requiring such measures?
11. Are proper records maintained of illnesses and accidents?
12. Are warning and accident prevention signs used to minimize work hazards?
13. Are personnel trained to follow appropriate biosafety practices?
14. Are laboratory staff encouraged to report potential exposures?

### **Laboratory equipment**

1. Is all equipment certified safe for use?
2. Are procedures available for decontaminating equipment prior to maintenance?
3. Are biological safety cabinets and fume cupboards regularly tested and serviced?
4. Are autoclaves and other pressure vessels regularly inspected?
5. Are centrifuge buckets and rotors regularly inspected?
6. Are HEPA filters regularly changed?
7. Are pipettes used instead of hypodermic needles?
8. Is cracked and chipped glassware always discarded and not reused?
9. Are there safe receptacles for broken glass?
10. Are plastics used instead of glass where feasible?
11. Are sharps disposal containers available and being used?

### **Infectious materials**

1. Are specimens received in a safe condition?
2. Are records kept of incoming materials?
3. Are specimens unpacked in biological safety cabinets with care and attention to possible breakage and leakage?
4. Are gloves and other protective clothing worn for unpacking specimens?
5. Are personnel trained to ship infectious substances according to current national and/or international regulations?
6. Are work benches kept clean and tidy?
7. Are discarded infectious materials removed daily or more often and disposed of safely?
8. Are all members of the staff aware of procedures for dealing with breakage and spillage of cultures and infectious materials?
9. Is the performance of sterilizers checked by the appropriate chemical, physical and biological indicators?
10. Is there a procedure for decontaminating centrifuges regularly?
11. Are sealed buckets provided for centrifuges?
12. Are appropriate disinfectants being used? Are they used correctly?
13. Is there special training for staff who work in containment laboratories – Biosafety Level 3 and maximum containment laboratories – Biosafety Level 4?

### **Chemicals and radioactive substances**

1. Are incompatible chemicals effectively separated when stored or handled?
2. Are all chemicals correctly labelled with names and warnings?
3. Are chemical hazard warning charts prominently displayed?
4. Are spill kits provided?
5. Are staff trained to deal with spills?
6. Are flammable substances correctly and safely stored in minimal amounts in approved cabinets?

## 22. SAFETY CHECKLIST

7. Are bottle carriers provided?
8. Is a radiation protection officer or appropriate reference manual available for consultation?
9. Are staff appropriately trained to safely work with radioactive materials?
10. Are proper records of stocks and use of radioactive substances maintained?
11. Are radioactivity screens provided?
12. Are personal radiation exposures monitored?





**PART IX**

References, annexes  
and index



# References

1. *Safety in health-care laboratories*. Geneva, World Health Organization, 1997, ([http://whqlibdoc.who.int/hq/1997/WHO\\_LAB\\_97.1.pdf](http://whqlibdoc.who.int/hq/1997/WHO_LAB_97.1.pdf)).
2. Garner JS, Hospital Infection Control Practices Advisory Committee. Guideline for isolation precautions in hospitals. *American Journal of Infection Control*, 1996, 24:24–52, (<http://www.cdc.gov/ncidod/hip/isolat/isolat.htm>).
3. Hunt GJ, Tabachnick WJ. Handling small arbovirus vectors safely during biosafety level 3 containment: *Culicoides variipennis sonorensis* (Diptera: Ceratopogonidae) and exotic blue-tongue viruses. *Journal of Medical Entomology*, 1996, 33:271–277.
4. National Research Council. *Occupational health and safety in the care and use of research animals*. Washington, DC, National Academy Press, 1997.
5. Richmond JY, Quimby F. Considerations for working safely with infectious disease agents in research animals. In: Zak O, Sande MA, eds. *Handbook of animal models of infection*. London, Academic Press, 1999:69–74.
6. *Biosafety in microbiological and biomedical laboratories*, 4th ed. Washington, DC, United States Department of Health and Human Services/Centers for Disease Control and Prevention/National Institutes of Health, 1999.
7. *Class II (laminar flow) biohazard cabinetry*. Ann Arbor, MI, National Sanitation Foundation, 2002 (NSF/ANSI 49–2002).
8. Richmond JY, McKinney RW. *Primary containment for biohazards: selection, installation and use of biological safety cabinets*, 2nd ed. Washington, DC, United States Department of Health and Human Services/Centers for Disease Control and Prevention/National Institutes of Health, 2000.
9. *Microbiological safety cabinets. Recommendations for information to be exchanged between purchaser, vendor and installer and recommendations for installation*. London, British Standards Institution, 1992 (Standard BS 5726–2:1992).
10. *Microbiological safety cabinets. Recommendations for selection, use and maintenance*. London, British Standards Institution, 1992 (Standard BS 5726–4:1992).
11. *Biological containment cabinets (Class I and II): installation and field testing*. Toronto, Canadian Standards Association, 1995 (Standard Z316.3–95 (R2000)).
12. Collins CH, Kennedy DA. *Laboratory acquired infections: history, incidence, causes and prevention*, 4th ed. Oxford, Butterworth-Heinemann, 1999.
13. Health Canada. *Laboratory biosafety manual*, 2nd ed. Ottawa, Minister of Supply and Services Canada, 1996.
14. *Biological safety cabinets – biological safety cabinets (Class I) for personnel and environment protection*. Sydney, Standards Australia International, 1994 (Standard AS 2252.1–1994).
15. *Biological safety cabinets – laminar flow biological safety cabinets (Class II) for personnel, environment and product protection*. Sydney, Standards Australia International, 1994 (Standard AS 2252.2–1994).

16. Standards Australia/Standards New Zealand. *Biological safety cabinets – installation and use*. Sydney, Standards Australia International, 2000 (Standard AS/NZS 2647:2000).
17. Advisory Committee on Dangerous Pathogens. *Guidance on the use, testing and maintenance of laboratory and animal flexible film isolators*. London, Health and Safety Executive, 1990.
18. Standards Australia/Standards New Zealand. *Safety in laboratories – microbiological aspects and containment facilities*. Sydney, Standards Australia International, 2002 (Standard AS/NZS 2243.3:2002).
19. Centers for Disease Control and Prevention. Recommendations for prevention of HIV transmission in health-care settings. *Morbidity and Mortality Weekly Report*, 1987, 36 (Suppl. 2):1S–18S.
20. Bosque PJ et al. Prions in skeletal muscle. *Proceedings of the National Academy of Sciences of the United States of America*, 2002, 99:3812–3817.
21. Bartz JC, Kincaid AE, Bessen RA. Rapid prion neuroinvasion following tongue infection. *Journal of Virology*, 2003, 77:583–591.
22. Thomzig A et al. Widespread PrP<sup>Sc</sup> accumulation in muscles of hamsters orally infected with scrapie. *EMBO Reports*, 2003, 4:530–533.
23. Glatzel M et al. Extraneural pathologic prion protein in sporadic Creutzfeld-Jakob disease. *New England Journal of Medicine*, 2003, 349:1812–1820.
24. Brown P, Wolff A, Gajdusek DC. A simple and effective method for inactivating virus infectivity in formalin-fixed tissue samples from patients with Creutzfeld-Jakob disease. *Neurology*, 1990, 40:887–890.
25. Taylor DM et al. The effect of formic acid on BSE and scrapie infectivity in fixed and unfixed brain-tissue. *Veterinary Microbiology*, 1997, 58:167–174.
26. Safar J et al. Prions. In: Richmond JY, McKinney RW, eds. *Biosafety in microbiological and biomedical laboratories*, 4th ed. Washington, DC, United States Department of Health and Human Services, 1999:134–143.
27. Bellinger-Kawahara C et al. Purified scrapie prions resist inactivation by UV irradiation. *Journal of Virology*, 1987, 61:159–166.
28. Health Services Advisory Committee. *Safe working and the prevention of infection in clinical laboratories*. London, HSE Books, 1991.
29. Russell AD, Hugo WB, Ayliffe GAJ. *Disinfection, preservation and sterilization*, 3rd ed. Oxford, Blackwell Scientific, 1999.
30. Ascenzi JM. *Handbook of disinfectants and antiseptics*. New York, NY, Marcel Dekker, 1996.
31. Block SS. *Disinfection, sterilization & preservation*, 5th ed. Philadelphia, PA, Lippincott Williams & Wilkins, 2001.
32. Rutala WA. APIC guideline for selection and use of disinfectants. 1994, 1995, and 1996 APIC Guidelines Committee. Association for Professionals in Infection Control and Epidemiology, INC. *American Journal of Infection Control*, 1996, 24:313–342.
33. Sattar SA, Springthorpe VS, Rochon M. A product based on accelerated and stabilized hydrogen peroxide: evidence for broad-spectrum germicidal activity. *Canadian Journal of Infection Control*, 1998, 13:123–130.
34. Schneider PM. Emerging low temperature sterilization technologies. In: Rutala WA, eds. *Disinfection & sterilization in health care*. Champlain, NY, Polyscience, 1997:79–92.
35. Springthorpe VS. New chemical germicides. In: Rutala WA, eds. *Disinfection & sterilization in health care*. Champlain, NY, Polyscience, 1997:273–280.



## REFERENCES

36. Steelman VM. Activity of sterilization processes and disinfectants against prions. In: Rutala WA, eds. *Disinfection & sterilization in health care*. Champlain, NY, Polyscience, 1997:255–271.
37. Taylor DM. Transmissible degenerative encephalopathies: inactivation of the unconventional causal agents. In: Russell AD, Hugo WB, Ayliffe GAJ, eds. *Disinfection, preservation and sterilization*, 3rd ed. Oxford, Blackwell Scientific, 1999:222–236.
38. *Infection control guidelines for hand washing, cleaning, disinfection and sterilization in health care*, 2nd ed. Ottawa, Laboratory Centre for Disease Control, Health Canada, 1998.
39. Springthorpe VS, Sattar SA. Chemical disinfection of virus-contaminated surfaces. *CRC Critical Reviews in Environmental Control*, 1990, 20:169–229.
40. *Recommendations on the transport of dangerous goods*, 13th revised edition, New York and Geneva, United Nations, 2003, ([http://www.unece.org/trans/danger/publi/unrec/rev13/13files\\_e.html](http://www.unece.org/trans/danger/publi/unrec/rev13/13files_e.html)).
41. *Technical instructions for the safe transport of dangerous goods by air*, 2003–2004 Edition. Montreal, International Civil Aviation Organization, 2002.
42. Economic Commission for Europe Inland Transport Committee. *Restructured ADR applicable as from 1 January 2003*. New York and Geneva, United Nations, 2002, (<http://www.unece.org/trans/danger/publi/adr/adr2003/ContentsE.html>).
43. *Infectious substances shipping guidelines*. Montreal, International Air Transport Association, 2003, (<http://www.iata.org/ads/issg.htm>).
44. *Transport of Infectious Substances*. Geneva, World Health Organization, 2004, ([http://www.who.int/csr/resources/publications/WHO\\_CDS\\_CSR\\_LYO\\_2004\\_9/en/](http://www.who.int/csr/resources/publications/WHO_CDS_CSR_LYO_2004_9/en/)).
45. Berg P et al. Asilomar conference on recombinant DNA molecules. *Science*, 1975, 188:991–994.
46. European Council. Council Directive 98/81/EC of 26 October 1998 amending Directive 90/219/EEC on the contained use of genetically modified microorganisms. *Official Journal*, 1998, L330:13–31.
47. O'Malley BW Jr et al. Limitations of adenovirus-mediated interleukin-2 gene therapy for oral cancer. *Laryngoscope*, 1999, 109:389–395.
48. World Health Organization. Maintenance and distribution of transgenic mice susceptible to human viruses: memorandum from a WHO meeting. *Bulletin of the World Health Organization*, 1993, 71:497–502.
49. Furr AK. *CRC handbook of laboratory safety*, 5th ed. Boca Raton, FL, CRC Press, 2000.
50. Lenga RE. *The Sigma-Aldrich Library of Chemical Safety Data*, 2nd ed. Milwaukee, WI, Aldrich Chemical Company, 1988.
51. Lewis RJ. *Sax's dangerous properties of industrial materials*, 10th ed. Toronto, John Wiley and Sons, 1999.

## ANNEX 1

# First aid

First aid is the skilled application of accepted principles of medical treatment at the time and place of an accident. It is the approved method of treating a casualty until he or she is placed in the care of a doctor for definitive treatment of the injury.

The minimum first-aid equipment consists of a first-aid box, protective clothing and safety equipment for the person rendering the first aid, and eye irrigation equipment.

### ***The first-aid box***

The first-aid box should be constructed from materials that will keep the contents dust- and damp-free. It should be kept in a prominent position and be easily recognized. By international convention, the first-aid box is identified by a white cross on a green background.

The first-aid box should contain:

1. Instruction sheet giving general guidance
2. Individually-wrapped sterile adhesive dressings in a variety of sizes
3. Sterile eye-pads with attachment bandages
4. Triangular bandages
5. Sterile wound coverings
6. Safety pins
7. A selection of sterile but unmedicated wound dressings
8. An authoritative first-aid manual, e.g. one issued by the International Red Cross.

Protective equipment for the person rendering first aid includes:

1. Mouthpiece for mouth-to-mouth resuscitation
2. Gloves and other barrier protections against blood exposures,<sup>1</sup> and
3. Clean-up kit for blood spills (see Chapter 14 of the manual).

Eye irrigation equipment should also be readily available and staff trained in its correct use.

---

<sup>1</sup> Garner JS, Hospital Infection Control Practices Advisory Committee. Guideline for isolation precautions in hospitals. *American Journal of Infection Control*, 1996, 24:24–52, (<http://www.cdc.gov/ncidod/hip/isolat/isolat.htm>).

## Immunization of staff

The risks of working with particular agents should be fully discussed with individual researchers. The local availability, licensing state and utility of possible vaccines and/or therapeutic drugs (e.g. antibiotic treatments) in case of exposure should be evaluated before work with such agents is started. Some workers may have acquired immunity from prior vaccination or infection.

If a particular vaccine or toxoid is locally licensed and available, it should be offered after a risk assessment of possible exposure and a clinical health assessment of the individual have been carried out.

Facilities for specific clinical case management following accidental infections should also be available.

## ANNEX 3

# WHO Biosafety Collaborating Centres

Information on the availability of training courses, aids and materials may be obtained by writing to any of the following:

- Biosafety programme, Department of Communicable Disease Surveillance and Response, World Health Organization, 20 Avenue Appia, 1211 Geneva 27, Switzerland (<http://www.who.int/csr/>).
- WHO Collaborating Centre for Biological Safety, Swedish Institute for Infectious Disease Control, Nobels Väg 18, S-171 82 Solna, Sweden (<http://www.smittskyddsinstitutet.se/English/english.htm>).
- WHO Collaborating Centre on Biosafety Technology and Consultative Services, Office of Laboratory Security, Health Canada, 100 Colonnade Road, Loc.: 6201A, Ottawa, Ontario, Canada K1A 0K9 (<http://www.hc-sc.gc.ca/pphb-dgsp/ols-bsl>).
- WHO Collaborating Centre for Applied Biosafety Programmes and Training, Office of Health and Safety, Centers for Disease Control and Prevention, 1600 Clifton Road, Mailstop F05, Atlanta, GA 30333, USA (<http://www.cdc.gov/>).
- WHO Collaborating Centre for Applied Biosafety Programmes and Research, Division of Occupational Health and Safety, Office of Research Services, National Institutes of Health, Department of Health and Human Services, 13/3K04 13 South Drive MSC 5760, Bethesda, MD 20892-5760, USA (<http://www.nih.gov/>).
- WHO Collaborating Centre for Biosafety, Victorian Infectious Diseases Reference Laboratory, 10 Wreckyn St, Nth Melbourne, Victoria 3051, Australia. Postal address: Locked Bag 815, PO Carlton Sth, Victoria 3053, Australia (<http://www.vidrl.org.au/>).

## ANNEX 4

# Equipment safety

Certain items of equipment may create microbiological hazards when they are used. Other items are specifically designed to prevent or reduce biological hazards (see Chapter 11 of the manual).

### Equipment that may create a hazard

Table A4-1 lists equipment and operations that may create hazards and suggests how such hazards may be eliminated or reduced.

*Table A4-1. Equipment and operations that may create hazards*

EQUIPMENT	HAZARD	HOW TO ELIMINATE OR REDUCE THE HAZARD
Hypodermic needles	Accidental inoculation, aerosol or spillage	<ul style="list-style-type: none"><li>• Do not recap or clip needles.</li><li>• Use a needle-locking type of syringe to prevent separation of needle and syringe, or use a disposable type where the needle is an integral part of the syringe unit.</li><li>• Use good laboratory techniques, e.g.:<ul style="list-style-type: none"><li>— fill the syringe carefully to minimize air bubbles and frothing of inoculum</li><li>— avoid using syringes to mix infectious liquids; if used, ensure that the tip of the needle is held under the surface of the fluid in the vessel and avoid excessive force</li><li>— wrap the needle and stopper in a cotton pledget moistened with an appropriate disinfectant before withdrawing the needle from a rubber-stoppered bottle</li><li>— expel excess liquid and air bubbles from the syringe vertically into a cotton pledget moistened with an appropriate disinfectant or into a small bottle containing cotton.</li></ul></li><li>• Use a biological safety cabinet for all operations with infectious material.</li></ul>

EQUIPMENT	HAZARD	HOW TO ELIMINATE OR REDUCE THE HAZARD
		<ul style="list-style-type: none"> <li>• Restrain animals while they are being inoculated. Use blunt needles or cannulas for intranasal or oral inoculation. Use a biological safety cabinet.</li> <li>• Autoclave after use and ensure proper disposal. If a disposable needle and syringe unit is used, do not disassemble prior to autoclaving.</li> </ul>
Centrifuges	Aerosols, splashing and tube breakage	<ul style="list-style-type: none"> <li>• Use sealable buckets (safety cups) or sealed rotors. Open buckets or rotors after aerosols have settled (30 min) or in a biological safety cabinet.</li> </ul>
Ultra-centrifuges	Aerosols, splashing and tube breakage	<ul style="list-style-type: none"> <li>• Install a HEPA filter between centrifuge and vacuum pump.</li> <li>• Maintain a logbook of operating hours for each rotor and a preventive maintenance programme to reduce risk of mechanical failure.</li> <li>• Load and unload buckets or rotors in a biological safety cabinet.</li> </ul>
Anaerobic jars	Explosion, dispersing infectious materials	<ul style="list-style-type: none"> <li>• Ensure integrity of wire capsule around catalyst.</li> </ul>
Desiccators	Implosion, dispersing glass fragments and infectious materials	<ul style="list-style-type: none"> <li>• Place in a stout wire cage.</li> </ul>
Homogenizer, tissue grinders	Aerosols, leakage and container breakage	<ul style="list-style-type: none"> <li>• Operate and open equipment in a biological safety cabinet.</li> <li>• Use specially designed models that prevent leakage from rotor bearings and O-ring gaskets, or use a stomacher.</li> <li>• Before opening the blender bowl, wait 30 min to allow the aerosol cloud to settle. Refrigerate to condense aerosols.</li> <li>• If manual tissue grinders are used, hold tube in a wad of absorbent material.</li> </ul>
Sonicators, ultrasonic cleaners	Aerosols, impaired hearing, dermatitis	<ul style="list-style-type: none"> <li>• Operate and open equipment in a biological safety cabinet or sealed unit.</li> <li>• Ensure insulation to protect against subharmonics.</li> <li>• Wear gloves to protect skin against chemical effects of detergents.</li> </ul>

#### ANNEX 4. EQUIPMENT SAFETY

EQUIPMENT	HAZARD	HOW TO ELIMINATE OR REDUCE THE HAZARD
Culture stirrers, shakers, agitators	Aerosols, splashing and spillage	<ul style="list-style-type: none"> <li>• Operate in a biological safety cabinet or specially designed primary containment.</li> <li>• Use heavy-duty screw-capped culture flasks, fitted with filter-protected outlets, if necessary, and well secured.</li> </ul>
Freeze-dryers (lyophilizers)	Aerosols and direct contact contamination	<ul style="list-style-type: none"> <li>• Use O-ring connectors to seal the unit throughout.</li> <li>• Use air filters to protect vacuum lines.</li> <li>• Use a satisfactory method of decontamination, e.g. chemical.</li> <li>• Provide an all-metal moisture trap and a vapour condenser.</li> <li>• Carefully inspect all glass vacuum vessels for surface scratches. Use only glassware designed for vacuum work.</li> </ul>
Water baths	Growth of micro-organisms. Sodium azide forms explosive compounds with some metals.	<ul style="list-style-type: none"> <li>• Ensure regular cleaning and disinfection.</li> <li>• Do not use sodium azide for preventing growth of organisms.</li> </ul>

In addition to microbiological hazards, safety hazards associated with equipment should also be anticipated and prevented. Table A4-2 lists examples of some of the causes of accidents.

**Table A4-2. Common causes of equipment-related accidents**

ACCIDENT	ACCIDENT CAUSE	REDUCING OR ELIMINATING THE HAZARD
<b><i>Faulty design or construction</i></b>		
Electrical fires in incubators	No over-temperature cut-out	• Compliance with national standards.
Electrical shock	Failure to provide reliable earthing/grounding	
<b><i>Improper use</i></b>		
Centrifuge accident	Failure to balance buckets on swing-out rotors	• Train and supervise staff.
Anaerobic incubator explosion	Use of incorrect gas	• Train and supervise staff.
<b><i>Improper adaptation</i></b>		
Explosion in domestic vacuum flask	Improper transport of liquid nitrogen	• Use of specially designed equipment.
Explosion in domestic-type refrigerator	Dangerous chemical not stored in spark-/explosion-proof container, e.g. diethyl ether with leaking screw cap	• Store low-flashpoint solvents and extracts only in spark-/explosion-proof refrigerators or cabinets.
<b><i>Lack of proper maintenance</i></b>		
Fire in flame photometer	Incorrect reassembly of components during maintenance	• Train and supervise staff.



## ANNEX 5

# Chemicals: hazards and precautions

This annex lists the basic health and safety information, data and appropriate safety precautions for a selected number of chemicals found commonly in health-care and research laboratories. The list is not exhaustive and the absence of any particular chemical does not imply that it is non-hazardous. All laboratory chemicals should be treated with caution and in ways that will minimize exposure.

**Table A5-1. Chemicals: hazards and precautions**

CHEMICAL	PHYSICAL PROPERTIES	HEALTH HAZARDS	FIRE HAZARDS	SAFETY PRECAUTIONS	INCOMPATIBLE CHEMICALS	OTHER HAZARDS
Acetaldehyde CH <sub>3</sub> CHO	Colourless liquid or gas with a pungent, fruity odour; m.p. -121 °C b.p. 21 °C.	Mild eye and respiratory tract irritation. Effects on the central nervous system, respiratory tract and kidneys. Possible carcinogen.	Extremely flammable; vapour/air mixtures are explosive; flash point -39 °C flammable range 4-57%.	No open flames, no sparks, no smoking, no contact with hot surfaces. Store in tightly sealed containers in areas separate from oxidizers; store only if stabilized. Use in exhaust cupboard or with good ventilation. Wear rubber gloves, safety goggles, and respiratory protection.	Can form explosive peroxides in contact with air. May polymerize under influence of acids, alkaline materials, in the presence of trace metals. A strong reducing agent, reacts violently with oxidants, with various organic substances, halogens, sulfuric acid and amines.	
Acetic acid CH <sub>3</sub> CO <sub>2</sub> H	Colourless liquid with pungent odour; m.p. 17 °C b.p. 118 °C; miscible with water.	Corrosive; causes severe burns; irritating vapour. Effects may be delayed.	Flammable; flashpoint 40 °C flammable range 5.4-16%.	Do not breathe fumes. In case of contact with eyes rinse immediately with water and seek medical advice. Wear nitrile gloves and eye protection.	Violent or explosive reaction with oxidizers.	
Acetic anhydride (CH <sub>3</sub> CO) <sub>2</sub> O	Colourless liquid with a strong pungent, vinegar-like odour; m.p. -73 °C b.p. 139 °C.	Severe irritation of eyes and upper respiratory tract irritation; corrosive action. Effects may be delayed.	Flammable; evolves irritation or toxic fumes or gases in a fire; flashpoint 49 °C explosive limits 2.7-10.3%.	No open flames, no sparks, no smoking. Prevent skin and eye contact.	Reacts violently with boiling water, steam, strong oxidants, alcohols, amines, strong bases and many other compounds. Attacks many metals in presence of water.	

## ANNEX 5. CHEMICALS: HAZARDS AND PRECAUTIONS

Acetone CH <sub>3</sub> COCH <sub>3</sub>	Colourless volatile liquid with sweetish odour; m.p. -95 °C, b.p. 56 °C.; miscible with water.	Slight eye, nose and throat irritation. Inhalation may cause dizziness, narcosis and coma.	Highly flammable; flashpoint -18 °C explosive limits 2.2-12.8%.	Keep container in well-ventilated area; keep away from sources of ignition. Do not breathe vapour. Use respiratory protection; wear eye protection.	Reacts violently with oxidizers (e.g. chromic and nitric acids) and chloroform in the presence of base. Incompatible with concentrated sulfuric and nitric acid mixtures.	Earth/ground large containers and vessels to prevent static electricity.
Acetonitrile CH <sub>3</sub> CN	Colourless liquid with an aromatic odour; m.p. -46 °C b.p. 82 °C.	Respiratory, eye and skin irritation. Exposure may result in convulsions, unconsciousness, cyanide poisoning.	Highly flammable; flashpoint 12.8 °C explosive limits 3.0-16%.	No open flames, no sparks, no smoking, no contact with oxidants. Use only in areas free of ignition sources. Store in tightly sealed containers in areas separate from oxidizers. Work with exhaust ventilation. Avoid skin, eye and mucous membrane contact. Use respiratory protection and rubber gloves.	Reacts with aqueous acids and bases, producing toxic fumes. Reacts with strong oxidants. Attacks some forms of plastic, rubber and coatings. Decomposes on burning producing hydrogen cyanide and nitrogen oxides.	
Acetylene HC≡CH	Colourless gas with a faint, ethereal or garlic-like odour; shipped under pressure, dissolved in acetone; m.p. -81 °C sublimes at -84 °C.	Simple asphyxiant; frostbite on skin contact.	Extremely flammable; flammable range 2.5-100%.	For skin protection use cold-insulating gloves and safety goggles or face shield. No open flames, no sparks, no smoking. Work with local exhaust ventilation, explosion-proof electrical equipment and lighting.	Strong reducing agent; reacts violently with oxidants and with fluorine or chlorine under influence of light. Reacts with copper, silver and mercury or their salts, forming shock-sensitive compounds.	

CHEMICAL	PHYSICAL PROPERTIES	HEALTH HAZARDS	FIRE HAZARDS	SAFETY PRECAUTIONS	INCOMPATIBLE CHEMICALS	OTHER HAZARDS
Acrolein $\text{CH}_2=\text{CHCHO}$	Colourless or yellow liquid with a piercing, disagreeable odour; m.p. $-87^\circ\text{C}$ b.p. $53^\circ\text{C}$ .	Lacrimation. Severe respiratory irritation; lung oedema at high exposure levels. Effects may be delayed.	Highly flammable; flashpoint $-26^\circ\text{C}$ explosive limits 2.8–31%.	Prevent skin and eye contact. Work in fume cupboard or with good ventilation.	Oxidizers, acids, alkalis, ammonia, amines. Polymerizes readily unless inhibited, usually with hydroquinone. May form shock-sensitive peroxides over time.	
Ammonia solutions	Colourless liquid with pungent odour; for gas: m.p. $-78^\circ\text{C}$ b.p. $-33^\circ\text{C}$ ; for 25% solution: m.p. $-58^\circ\text{C}$ b.p. $38^\circ\text{C}$ ; miscible with water.	Corrosive to eyes, respiratory system and skin on ingestion; lung oedema at high levels of exposure to gas or vapour.	As ammonia gas; flammable range 15–28%.	Keep container tightly closed. In case of contact with eyes, rinse immediately and seek medical advice. Work in fume cupboard. Wear rubber or plastic gloves and chemical-grade goggles.	Reacts violently with heavy metals such as mercury and their salts to form explosive products.	
Aniline $\text{C}_6\text{H}_5\text{NH}_2$	Colourless to brown, oily liquid with an aromatic amine-like odour; m.p. $-6^\circ\text{C}$ b.p. $185^\circ\text{C}$ .	Cyanosis due to methaemoglobinemia. Eye and skin irritation. May be absorbed through the skin; repeated or prolonged exposure may cause sensitization.	Combustible; flashpoint $70^\circ\text{C}$ explosive range 1.2–11%.	Store in tightly sealed containers in areas separate from oxidizers. Prevent skin and eye contact. Work with local exhaust ventilation or respiratory protection, protective gloves, protective clothing, face shield.	Strong oxidizers, strong acids.	
Auramine 4,4'-Carbonyl- imidoyl-bis (N,N-dimethyl- benzenamine)	Yellow flakes or powder; m.p. $136^\circ\text{C}$ ; insoluble in water.	Harmful by ingestion, inhalation and skin contact. May cause eye or skin irritation. Possible carcinogen.		Avoid skin contact and inhalation of dust. Wear rubber or plastic gloves and chemical-grade goggles. Work in fume cupboard or wear dust respirator.	Strong oxidizing agents.	

Benzene C <sub>6</sub> H <sub>6</sub>	Colourless volatile liquid with characteristic aromatic odour; m.p. 6 °C; b.p. 80 °C.	Inhalation of vapour causes effects on central nervous system resulting in vertigo and headache; at high concentrations, unconsciousness and death. Risk of aplastic anaemia, leukaemia, liver damage on prolonged or chronic exposure. May be absorbed through skin.	Highly flammable; flashpoint -11 °C flammable range 1.3-8%.	Keep container in well-ventilated area and away from sources of ignition. Work in fume cupboard or hood with adequate ventilation. Wear eye protection and nitrile or PVC gloves. Prevent formation of electrical charges by earthing/grounding.	Can react violently with oxidizers including chromic acid, potassium permanganate and liquid oxygen.
Benzidine 1,1'-Biphenyl-4,4'-diamine	Light yellow powder; m.p. 128 °C; b.p. 400 °C; slightly soluble in water but very soluble in acids and organic solvents.	May be absorbed through skin. May cause bladder cancer. Avoid all exposure.	Combustible, gives off toxic fumes (gases) in a fire.	Avoid all exposure. Wear eye and skin protection. Work in fume cupboard with exhaust ventilation.	Use is prohibited or legally controlled in many countries.
Bromine Br <sub>2</sub>	Dark reddish-brown fuming liquid with pungent odour; m.p. -7.2 °C; b.p. 58.8 °C.	Corrosive. Vapour is corrosive to eyes and respiratory tract; inhalation may cause lung oedema and effects on central nervous system. Eye contact can cause blurred vision, redness, pain, severe tissue burns.	Not combustible but enhances combustion of other substances. Many reactions may cause fire or explosion. Heating will cause rise in pressure with risk of burning.	Use in closed system and with ventilation. Wear protective gloves and clothing, safety goggles, face shield or eye protection in combination with respiratory protection.	Strong oxidant, reacts violently with combustible and reducing materials. Reacts violently with aqueous ammonia, oxidants, metals, organic compounds and phosphorus. Attacks some forms of plastic, rubber and coatings.

CHEMICAL	PHYSICAL PROPERTIES	HEALTH HAZARDS	FIRE HAZARDS	SAFETY PRECAUTIONS	INCOMPATIBLE CHEMICALS	OTHER HAZARDS
Carbon dioxide (solid; "dry ice") CO <sub>2</sub>	Translucent white solid at -79 °C; sublimates to gas at ambient temperature.	Risk of asphyxiation in confined or poorly ventilated areas; contact with solid "dry ice" causes frostbite.		Wear protective insulated gloves. Store only in ventilated room or area in open container.	Alkali metals, strong bases.	
Carbon tetrachloride CCl <sub>4</sub>	Colourless liquid with characteristic ether-like odour; m.p. -23 °C b.p. 76.5 °C.	May be absorbed through skin; may cause dermatitis on prolonged exposure. Eye irritation. May cause liver and kidney damage and central nervous system disturbances resulting in headache, nausea, slight jaundice, loss of appetite and narcosis. An animal carcinogen.	Not combustible. Gives off irritating or toxic fumes or gases in a fire.	Avoid all contact. Work with ventilation, local exhaust or respiratory protection; use nitrile gloves and protective clothing, face shield or eye protection in combination with respiratory protection.	On contact with hot surfaces or flames, decomposes forming toxic and corrosive fumes and gases (hydrogen chloride, chlorine, phosgene). Reacts with some metals such as aluminium, magnesium, zinc.	
Chlorine Cl <sub>2</sub>	Greenish-yellow gas with pungent odour; m.p. -101 °C b.p. -34 °C.	Corrosive to eyes, skin and respiratory tract. Inhalation of gas may cause pneumonitis and lung oedema, resulting in reactive airways dysfunction syndrome (RAADS). Rapid evaporation of the liquid may cause frostbite. High exposures may result in death. Effects may be delayed; medical observation indicated.	Not combustible but enhances combustion of other substances.	Work with closed system and ventilation. Wear cold-insulating gloves, protective clothing, eye safety goggles or eye protection in combination with respiratory protection.	Solution in water is a strong acid, reacts violently with bases and many organic compounds, acetylene, butadiene, benzene and other petroleum fractions, ammonia, hydrogen, sodium carbide, turpentine and finely divided metals causing fire and explosion hazard.	Attacks many metals in presence of water. Attacks plastics, rubber and coatings.

ANNEX 5. CHEMICALS: HAZARDS AND PRECAUTIONS

Chlorine dioxide ClO <sub>2</sub>	Yellow to red gas or a red-brown liquid; m.p. -59 °C b.p. 10 °C.	Severe irritation of eyes, skin and respiratory tract; inhalation of gas may cause lung oedema. Effects may be delayed; medical observation indicated.	Not combustible but enhances combustion of other substances; may explode on heating, on exposure to sunlight or if subjected to shock and sparks.	Work in closed system with ventilation. Wear protective gloves and clothing, safety goggles or eye protection in combination with respiratory protection.	A strong oxidant; reacts violently with combustible and reducing materials. Reacts violently with phosphorus, potassium hydroxide, sulfur, ammonia, methane, phosphine and hydrogen sulfide.
Chloroform CHCl <sub>3</sub>	Colourless volatile liquid with characteristic odour; m.p. -63 °C; b.p. 61 °C; slightly soluble in water.	Harmful by inhalation, ingestion and skin contact; skin irritation. May cause effects on liver, kidneys and central nervous system resulting in headache, nausea, slight jaundice, loss of appetite, narcosis. Prolonged or chronic exposure causes cancer in animals; suspected human carcinogen.		Wear protective clothing, nitrile gloves and eye protection. Work in a fume cupboard.	Strong bases; some metals such as aluminium or magnesium, zinc powder; strong oxidizers. When heated to decomposition, forms phosgene gas. Attacks plastics, rubber.
Chromic acid CrO <sub>3</sub> Chromium VI oxide	Dark red odourless flakes or powder often used in aqueous solutions; m.p. 197 °C.	Irritation of eyes, skin and respiratory system. Repeated or prolonged contact with skin may cause dermatitis, chrome ulcers and skin sensitization. Inhalation may cause asthma-like reactions. May cause perforation of nasal septum. Human carcinogen.	Decomposes above 250 °C to chromic oxide and oxygen with increased fire hazard. Many reactions may cause hazards.	Prevent skin and eye contact; avoid inhalation of fine dust and mist. Work with ventilation, local exhaust or respiratory protection.	In aqueous solution is a strong acid which reacts with bases and is corrosive. Strong oxidant, reacts with combustible, organic or other readily oxidizable materials (paper, wood, sulfur, aluminium, plastics etc.). Corrosive to metals.

CHEMICAL	PHYSICAL PROPERTIES	HEALTH HAZARDS	FIRE HAZARDS	SAFETY PRECAUTIONS	INCOMPATIBLE CHEMICALS	OTHER HAZARDS
Copper Cu	Reddish, lustrous, malleable, odourless solid; red powder, turns green on exposure to moist air; m.p. 1083 °C b.p. 2567 °C.	Inhalation of copper fume may cause metal fume fever.	Combustible.	Work with local exhaust or respiratory protection, protective gloves and goggles.	Shock-sensitive compounds are formed with acetylenic compounds, ethylene oxides azides and hydrogen peroxide. Reacts with strong oxidants like chlorates, bromates and iodates, causing explosion hazard.	
Cyanogen bromide BrCN	Colourless or white crystals, with pungent odour; m.p. 52 °C b.p. 61 °C.	Severe eye, skin and respiratory tract effects; inhalation of vapour may cause lung oedema which may result in convulsions, unconsciousness, respiratory failure and death.	Not combustible but forms flammable gas on heating. Gives off irritating or toxic fumes or gases in a fire.	Work in closed system with ventilation. Wear protective gloves and protective clothing, safety goggles face shield or eye protection in combination with respiratory protection.	Decomposes on heating and on contact with acids producing highly toxic and flammable hydrogen cyanide and corrosive hydrogen bromide. Reacts with strong oxidants. Reacts slowly with water and moisture to produce hydrogen bromide and hydrogen cyanide. Attacks many metals in the presence of water.	
Cytochalasin (A–J)	White powder; m.p. varies.	Toxic by ingestion, inhalation or absorption through skin. May cause congenital fetal malformation.		Avoid contact with eyes, skin, clothing; wear chemical-grade goggles and rubber or plastic gloves.	Strong oxidizing agents.	



Diethyl ether $C_2H_5OC_2H_5$	Colourless highly volatile liquid with sweet characteristic odour; m.p. $-116\text{ }^\circ\text{C}$ b.p. $34\text{ }^\circ\text{C}$ ; slightly soluble in water.	Irritation of eyes and respiratory tract. May affect central nervous system causing drowsiness and unconsciousness. Repeated inhalation may cause addiction.	Extremely flammable; flashpoint $-45\text{ }^\circ\text{C}$ flammable range 1.7–48%.	Keep container in well-ventilated area; keep away from sources of ignition; earth/ground containers to prevent static electrical discharges. Work in fume cupboard. Wear nitrile gloves to prevent defatting of skin.	Exposure to air and light may result in formation of explosive peroxides. Can react violently with oxidizers and halogens.
Dimethylamine $(CH_3)_2NH$	Colourless volatile liquefied gas with pungent odour; m.p. $-93\text{ }^\circ\text{C}$ b.p. $7\text{ }^\circ\text{C}$ ; miscible with water.	Severe irritation of eyes and respiratory system; inhalation may cause lung oedema. Rapid evaporation may cause frostbite. Solution is corrosive to eyes and skin.	Extremely flammable; flashpoint $-26\text{ }^\circ\text{C}$ flammable limits 2.8–14%. Solution highly flammable; flashpoint $-18\text{ }^\circ\text{C}$ .	Keep away from sources of ignition; in case of contact with eyes rinse immediately and seek medical advice. Work in fume cupboard. Wear nitrile gloves and chemical-grade goggles.	Can react with oxidizers, mercury.
2,4-Dinitro-phenyl-hydrazine $C_6H_3(NO_2)_2NHNH_2$ 1-Hydrazino-2,4-dinitrobenzene	Orange-red crystalline powder; m.p. $200\text{ }^\circ\text{C}$ ; slightly soluble in water.	Irritation of skin and eyes. Harmful by ingestion, inhalation and skin contact.		Keep moist to reduce explosion risk. Wear dust respirator, rubber or plastic gloves and chemical-grade goggles.	Can react vigorously with oxidizers and reducers.

CHEMICAL	PHYSICAL PROPERTIES	HEALTH HAZARDS	FIRE HAZARDS	SAFETY PRECAUTIONS	INCOMPATIBLE CHEMICALS	OTHER HAZARDS
Dioxane $C_4H_8O_2$ Diethylene dioxide	Colourless liquid, with characteristic odour, m.p. 12 °C b.p. 101 °C.	Irritation of eyes and respiratory tract. May affect central nervous system resulting in headache, nausea, cough, sore throat, abdominal pain, dizziness, drowsiness, vomiting, unconscious- ness. May be absorbed through skin. Kidney and liver damage. Probably a human carcinogen.	Highly flammable; distant ignition possible; as a result of flow, agitation, etc., electrostatic charges can be generated.	Work with ventilation, local exhaust. No open flames, no sparks, no smoking, no contact with strong oxidants or hot surfaces. Do not use compressed air for filling, discharging or handling. Use non-sparking tools. Wear protective gloves, clothing, face shield or eye protection, in combination with respiratory protection.	Can form explosive peroxides. Reacts vigorously with strong oxidants and concentrated strong acids. Reacts explosively with some catalysts. Attacks many plastics.	
Ethanol $CH_3CH_2OH$	Colourless volatile liquid with slight, characteristic odour; m.p. -117 °C b.p. 79 °C; miscible with water.	Harmful if ingested. Irritation of eyes. May affect central nervous system.	Highly flammable; flashpoint 12 °C flammable limits 3–19%.	Keep container tightly closed; keep away from ignition sources.	Reacts violently with strong oxidizers.	
Ethanolamine $H_2NCH_2CH_2OH$ 2-Amino- ethanol	Colourless non-volatile viscous liquid with ammoniacal odour; m.p. 10 °C b.p. 171 °C; miscible with water.	Corrosive to eyes, respiratory system and skin. May cause skin sensitization.	Flashpoint 85 °C.	Wear rubber or plastic gloves and eye protection.	Reacts with strong oxidizers.	

## ANNEX 5. CHEMICALS: HAZARDS AND PRECAUTIONS

<p>Formaldehyde solution (37–41% formaldehyde with 11–14% methanol) HCHO</p>	<p>Colourless liquid with a pungent odour; b.p. 96 °C; miscible with water.</p>	<p>Severely irritation of eyes and skin, irritation of respiratory tract; prolonged exposure to the vapour may cause asthma-like symptoms, conjunctivitis, laryngitis, bronchitis or bronchopneumonia. May cause sensitization by skin contact. Possible risk of irreversible health effects. Possible carcinogen.</p>	<p>Flashpoint 50 °C.</p>	<p>Wear protective clothing such as plastic apron, rubber or plastic gloves and chemical-grade goggles. Work in fume cupboard or well-ventilated area.</p>	<p>Can react vigorously with oxidizers, with nitromethane to produce explosive products, with hydrochloric acid to produce the potent carcinogen <i>bis</i> (chloromethyl) ether.</p>	<p>Concentrated formaldehyde solutions become cloudy if stored below 21 °C and should be kept at 21–25 °C. Dilute solutions (1–5%) and medium-strength solutions (5–25%) retain many of the hazards of the concentrated form.</p>
<p>Glutaraldehyde <math>\text{OHC}(\text{CH}_2)_3\text{CHO}</math></p>	<p>Colourless or pale yellow solution with pungent odour; m.p. –14 °C; b.p. 189 °C; miscible with water.</p>	<p>Severe irritation of eyes and upper respiratory tract; prolonged inhalation exposure or skin contact may cause sensitization.</p>		<p>Work in fume cupboard or well-ventilated area. Wear rubber or plastic gloves and eye protection.</p>	<p>Can react vigorously with oxidizers.</p>	<p>Often supplied in aqueous solution at various concentrations with added stabilizer to enhance stability.</p>
<p>Hydrochloric acid (10–37%) HCl Hydrogen chloride</p>	<p>Colourless fuming liquid with a pungent odour; b.p. –121 °C; miscible with water.</p>	<p>Corrosive to eyes, respiratory system and skin; repeated inhalation of vapour can cause chronic bronchitis.</p>		<p>Do not breathe fumes; use respiratory protection. In case of contact with eyes, rinse immediately with water and seek medical advice; in case of contact with skin, wash immediately with plenty of water. Work in fume cupboard. Wear rubber or plastic gloves and eye protection (spectacles or goggles).</p>	<p>Reacts violently with bases (solids and concentrated solutions), explosively with solid potassium permanganate. Gives off toxic or explosive gases on contact with many metals.</p>	<p>Releases highly toxic fumes in fires.</p>

CHEMICAL	PHYSICAL PROPERTIES	HEALTH HAZARDS	FIRE HAZARDS	SAFETY PRECAUTIONS	INCOMPATIBLE CHEMICALS	OTHER HAZARDS
Hydrogen peroxide $H_2O_2$	Colourless liquid; m.p. $-39\text{ }^\circ\text{C}$ ( $70\%$ ) b.p. $125\text{ }^\circ\text{C}$ ( $70\%$ ); miscible with water, supplied in aqueous solution at various concentrations.	Corrosive at high concentration ( $60\%$ ), and at low concentration ( $6\%$ ) if contact with skin is prolonged. Dilute solutions are irritating to eyes, respiratory system and skin.	Oxidizing agent; contact with combustible material can cause fire.	In case of contact with skin, wash immediately with plenty of water. Wear nitrile gloves and eye protection if concentration exceeds $20\%$ .	Reacts vigorously with a variety of chemical reagents including oxidizers and bases. Attacks most metals or their salts, flammable liquids and other combustible materials (paper, textiles), aniline and nitromethane.	Can decompose evolving oxygen, causing pressure rise in container. Store in dark, cool place. Do not use metallic containers or equipment, e.g. brass, copper, iron.
Hydrogen sulfide $H_2S$	Colourless gas with a strong odour of rotten eggs; b.p. $-60\text{ }^\circ\text{C}$ m.p. $-85\text{ }^\circ\text{C}$ .	May cause effects on central nervous system resulting in headache, dizziness, cough, sore throat, nausea, laboured breathing, unconsciousness and death. Inhalation may cause lung oedema. Redness, pain, severe deep burns of eyes.	Extremely flammable; explosive limits $4.3\text{--}46\%$ .	Work with ventilation, local exhaust. Wear safety goggles or eye protection in combination with respiratory protection.	Strong oxidizers and strong nitric acid. Attacks many metals and plastics.	Sense of smell becomes rapidly fatigued and cannot be relied on to warn of the continuous presence of the gas.
Iodine $I_2$	Bluish-black crystalline scales with a characteristic odour; m.p. $114\text{ }^\circ\text{C}$ b.p. $184\text{ }^\circ\text{C}$ ; practically insoluble in water.	Irritation of eyes, respiratory system and skin. Repeated exposure may cause skin sensitization. May have effect on thyroid.	Not combustible but enhances combustion of other substances. Many reactions may cause fire or explosion. Gives off irritating or toxic fumes (or gases) in a fire.	Do not breathe vapour; avoid contact with eyes. Wear nitrile gloves.	Reacts violently with metals including aluminium, potassium and sodium, and with ethanol/phosphorus mixtures, acetylene and ammonia.	

## ANNEX 5. CHEMICALS: HAZARDS AND PRECAUTIONS

<p>Mercury Hg (Quicksilver)</p>	<p>Heavy silvery liquid; m.p. -39 °C b.p. 357 °C; insoluble in water.</p>	<p>May be absorbed through skin. Repeated exposure may affect kidneys and central nervous system, and may cause vomiting, diarrhoea, headache, nausea, swollen gums, loose teeth.</p>	<p>Not combustible. Gives off irritating or toxic fumes in a fire.</p>	<p>Keep container tightly closed. Work in fume cupboard or well-ventilated area. Prevent spills. Observe strict hygiene. Wear nitrile gloves.</p>	<p>Acetylene, fulminic acid. Reacts with ammonia, azides and ethylene oxide to form explosive products. Reacts violently with bromine. Forms amalgams with many metals.</p>	<p>Store containers and use over catchment trays to contain spillage; suck up spill drop-lets into a small respiratory bottle fitted with a capillary connecting tube and connected to a pump; treat spilt areas with zinc dust to form an amalgam.</p>
<p>Methanol CH<sub>3</sub>OH</p>	<p>Colourless volatile liquid with characteristic odour; m.p. -98 °C b.p. 65 °C; miscible with water.</p>	<p>Effects on central nervous system resulting in unconsciousness; mucous membrane irritation. Chronic exposure can cause damage to retina and optic nerve. Prolonged skin contact may cause dermatitis. May be absorbed through skin.</p>	<p>Highly flammable; flashpoint -16 °C flammable range 7-37%.</p>	<p>Keep container tightly closed; keep away from ignition sources. Avoid breathing vapour and contact with skin. Work in fume cupboard or well-ventilated area. Wear rubber or plastic gloves and eye protection.</p>	<p>Can react vigorously with oxidizers. Reactions with magnesium or bromine can be violent and those with strong oxidants or chloroform with sodium can be explosive.</p>	
<p>Naphthylamine (alpha and beta) C<sub>10</sub>H<sub>7</sub>N <i>M</i>-phenyl-<math>\alpha</math>-naphthylamine and <i>M</i>-phenyl-<math>\beta</math>-naphthylamine</p>	<p>White to pink crystals with characteristic odour; alpha: m.p. 50 °C b.p. 301 °C; beta: m.p. 113 °C b.p. 306 °C; poorly soluble in water but hydrochloride is water-soluble.</p>	<p>Both forms very toxic by inhalation, ingestion and skin contact. Human carcinogen causing bladder cancer. Experimental mutagen and teratogen. Absorbed through skin.</p>	<p>Combustible.</p>	<p>Avoid all exposure; wear suitable protective clothing. Work in fume cupboard or hood, or with exhaust ventilation.</p>	<p>Use is prohibited or legally controlled in many countries.</p>	

CHEMICAL	PHYSICAL PROPERTIES	HEALTH HAZARDS	FIRE HAZARDS	SAFETY PRECAUTIONS	INCOMPATIBLE CHEMICALS	OTHER HAZARDS
Nimhydrin $C_9H_6O_4$	Pale yellow solid, decomposes before melting at 241 °C. Supplied in aerosol spray cans as 0.5% solution in butanol; soluble in water.	Harmful by ingestion and inhalation. Irritation of eyes, respiratory system and skin. Repeated exposure may cause skin sensitization.	Flammable, combustible solid; flashpoint 39 °C.	Avoid inhalation of the spray or vapour and contact with eyes. Wear rubber or plastic gloves and chemical-grade goggles.		Contact with skin produces a persistent violet stain.
Nitric acid (50–70%) $HNO_3$	Colourless or pale yellow fuming liquid; m.p. –42 °C; b.p. 83–121 °C; miscible in water.	Corrosive; causes severe burns to eyes and skin. Inhalation of vapour may cause lung oedema.	Oxidizer; contact with combustible material may cause fire. Evolves toxic fumes in a fire.	Do not breathe vapour; use respiratory protection. In case of contact with eyes, rinse immediately and seek medical attention; in case of contact with skin, wash off immediately; remove contaminated clothing. Wear PVC gloves, plastic apron and chemical-grade goggles. Work in fume cupboard.	Acetic acid, chromic acid, hydrocyanic acid, aniline, carbon, hydrogen sulfide, bases, metals and many other substances.	Concentrated nitric acid is involved in more dangerous reactions than any other chemical reagent.
Nitrobenzene $C_6H_5NO_2$	Pale yellow oily liquid, with characteristic odour; m.p. 6 °C; b.p. 211 °C.	Methaemoglobinaemia with cyanosis, liver damage; symptoms include blue lips or fingernails, blue skin, dizziness, nausea, weakness, unconsciousness. Absorbed through skin.	Combustible; risk of fire and explosion; flashpoint 88 °C.	Work with ventilation, local exhaust or respiratory protection. Wear protective gloves, protective clothing, safety goggles.	On combustion forms corrosive fumes including nitrogen oxides. Reacts violently with strong oxidants and reducing agents, causing fire and explosion hazard. Attacks many plastics. Forms explosive (thermally unstable) substances or mixtures with many organic and inorganic compounds.	

Osmium tetroxide $\text{OsO}_4$	Pale yellow crystals with pungent odour; m.p. 40 °C b.p. 130 °C; sublimes below boiling point; soluble in water.	Very toxic by inhalation, ingestion and skin contact, causing severe burns and irritation. Vapour, solid and solutions are corrosive to skin and respiratory tract. Inhalation may cause lung oedema.	Powerful oxidizing agent. Not combustible but enhances combustion of other substances.	Keep container tightly closed and in a well-ventilated area. Work with solid and solutions in fume cupboard or hood. Wear chemical-grade goggles and protective gloves. To make up solutions, add unopened ampoule to required volume of water, stopper and shake to break ampoule.
Oxalic acid $\text{HO}_2\text{C}_2\text{O}_2\text{H}$	Colourless crystals; soluble in water; m.p. 190 °C, decomposes.	Harmful if in contact with skin or if ingested. Dust irritates respiratory tract and eyes. Solutions irritate eyes and may cause skin burns.	Combustible. Gives off irritating or toxic fumes (or gases) in a fire.	Avoid contact with skin and eyes; wear eye protection and gloves. Oxidizing agents; also silver and mercury and their compounds.
Oxygen $\text{O}_2$	Colourless compressed gas; m.p. -218.4 °C b.p. -183 °C.	At very high concentrations, irritation of respiratory tract.	Not combustible but enhances combustion of other substances. Heating will cause rise in pressure of container with risk of bursting.	A strong oxidant, reacts with combustible and reducing materials, causing fire and explosion hazard. Reacts with oils, greases, hydrogen, and flammable liquids, solids and gases.

CHEMICAL	PHYSICAL PROPERTIES	HEALTH HAZARDS	FIRE HAZARDS	SAFETY PRECAUTIONS	INCOMPATIBLE CHEMICALS	OTHER HAZARDS
Perchloric acid $\text{HClO}_4$	Colourless liquid; miscible with water.	Corrosive; causes severe burns to eyes and skin and if ingested. Vapour is corrosive to eyes, skin, and respiratory tract. Inhalation of vapours may cause lung oedema.	Powerful oxidizing agent. Not combustible but enhances combustion of other substances.	Avoid breathing vapour and other exposure; wear protective clothing including nitrile gloves, eye and face protection. With hot solutions work in fume cupboard or hood.	Combustible materials and reducing agents: acetic anhydride, bismuth and its alloys, alcohol, metal, paper, wood and other organic materials.	Powerful oxidizing agent; may form explosive products if in contact with many inorganic and organic materials; contaminated wooden floors, benches, etc. May explode on percussion.
Phenol $\text{C}_6\text{H}_5\text{OH}$	Colourless or pale pink crystals with characteristic odour; m.p. $41^\circ\text{C}$ ; b.p. $182^\circ\text{C}$ ; soluble in water.	Substance and vapours are corrosive to eyes, skin and respiratory tract causing severe burns; absorbed through skin. Central nervous system disturbance, coma. Kidney and liver damage. Symptoms include abdominal pain, vomiting, diarrhoea, skin irritation, eye pain. Prolonged contact with dilute solutions may cause dermatitis.	Flashpoint $80^\circ\text{C}$ flammable range 1.7–6%.	Do not breathe vapour; use respiratory protection. Avoid eye and skin contact. Work in fume cupboard. Wear nitrile gloves and eye protection. In case of contact with eyes, rinse immediately with water and seek medical advice; in case of contact with skin, remove any contaminated clothing and swab the contaminated area with glycerol, polyethylene glycol 300 or a mixture of liquid polyethylene glycol (70%) and methylated spirit (30%) and then flush with water.	Reacts with oxidants causing fire and explosion hazard.	



ANNEX 5. CHEMICALS: HAZARDS AND PRECAUTIONS

Phosphoric acid $H_3PO_4$	Colourless viscous liquid or hygroscopic white crystals; m.p. 42 °C decomposes below boiling point at 213 °C; soluble in water.	Corrosive; causes burns to the skin and eyes.	Attacks many metals producing hydrogen. Gives off toxic fumes in a fire.	In case of contact with eyes, rinse with water and obtain medical advice. Wear nitrile gloves and eye protection.	Solution in water is a strong acid; reacts violently with bases and is corrosive. Reacts violently with perchloric acid causing fire and explosion hazard. Reacts violently with water forming phosphoric acid. Attacks many metals in presence of water.
Phosphorus pentoxide $P_2O_5$	Hygroscopic white crystals or powder; m.p. 340 °C, sublimation point 360 °C.	Corrosive to the eyes, skin, respiratory tract, leading to sore throat, cough, burning sensation, shortness of breath; skin burns, pain, blisters, eye burns. Inhalation may cause lung oedema. Ingestion may cause abdominal cramps, burning sensation, diarrhoea, sore throat, vomiting.	Not combustible but enhances combustion of other substances. Many reactions may cause fire or explosion. Gives off irritating or toxic fumes (or gases) in a fire.	Work with local exhaust protection. Wear protective gloves and clothing, face shield, or eye protection in combination with respiratory protection.	
Picric acid $C_6H_2(NO_2)_3OH$ 2,4,6-Trinitrophenol	Yellow crystals moistened with water or dissolved in alcohol; m.p. 122 °C; slightly soluble in water.	Toxic by ingestion, inhalation or skin contact. Ingestion may result in headache, nausea. Irritation of eyes.	Explosive when dry.	Keep moistened with water at all times or use only in alcoholic solution.	Forms salts with many metals which are more explosive than the acid itself. In contact with concrete may form calcium picrate, which is a friction-sensitive explosive. May react vigorously with reducing agents.

CHEMICAL	PHYSICAL PROPERTIES	HEALTH HAZARDS	FIRE HAZARDS	SAFETY PRECAUTIONS	INCOMPATIBLE CHEMICALS	OTHER HAZARDS
Potassium hydroxide KOH	White flakes, powder, pellets or sticks; m.p. 360 °C b.p. 1320 °C; very soluble in water.	Corrosive to respiratory system, eyes and skin; inhalation of dust causes lung oedema.		In case of contact with eyes, rinse immediately with water and seek medical advice; in case of contact with skin, wash immediately; remove contaminated clothing. Wear rubber or plastic gloves and eye protection even for dilute solutions.	Reacts violently with acids and with nitrobenzene and many other detergents. Evolves large quantity of heat when mixed with water; store in a well-sealed container.	Attacks some metals (aluminium, zinc, tin) in the presence of moisture.
Potassium permanganate KMnO <sub>4</sub>	Purple crystals; m.p. 240 °C (decomposes); readily soluble in water.	Corrosive if swallowed or if dust is inhaled. Extreme irritation of eyes and respiratory tract, inhalation of dust may cause lung oedema.	Powerful oxidizing agent; may ignite combustible materials.	Wear protective clothing, eye protection and particulate respirator if dust is produced.	Reacts violently or explosively if mixed with a wide variety of inorganic and organic compounds or powdered metals.	
Potassium tellurite K <sub>2</sub> TeO <sub>3</sub>	White deliquescent crystals; very soluble in water.	Toxic by ingestion and inhalation of dust. Irritation of skin and eyes.		Wear protective clothing.		
Propan-2-ol (CH <sub>3</sub> ) <sub>2</sub> CHOH Isopropanol	Colourless liquid with alcoholic odour; m.p. -89 °C b.p 82 °C; miscible with water.	Irritation of eyes and respiratory tract. May affect central nervous system causing headache, dizziness, nausea, vomiting and coma.	Highly flammable; flashpoint 112 °C flammable range 2.3-12.7%.	Keep container tightly closed; keep away from ignition sources. Work in fume cupboard. Wear nitrile gloves and eye protection.	Can react vigorously with oxidizers to form unstable peroxides on prolonged exposure to air and light.	70-85% propan-2-ol in water used as a disinfectant spray remains a flammable hazard and should not be used near ignition sources.

Pyridine C <sub>5</sub> H <sub>5</sub> N	Colourless liquid with characteristic odour; m.p. 42 °C b.p. 115 °C.	Affects central nervous system causing dizziness, headache, nausea, shortness of breath, unconsciousness. May be absorbed through skin causing redness and burning sensation. Ingestion causes abdominal pain, diarrhoea, vomiting, weakness. Repeated exposure causes liver and kidney effects.	Highly flammable; flashpoint 20 °C explosive limits, 1.8–12.4%. Gives off irritating or toxic fumes (or gases) in a fire. Vapour/ mixtures are explosive.	Work with ventilation, local exhaust or respiratory protection; wear gloves and protective clothing.	Reacts violently with strong oxidants and strong acids.
Selenium Se	Odourless solid in various forms, dark red-brown to bluish-black amorphous solid or red transparent crystals or metallic grey to black crystals; m.p. 170–217 °C b.p. 685 °C.	Irritation of skin and eye. Inhalation of dust may cause lung oedema. Repeated exposure may cause loss of nails, gastrointestinal effects.	Combustible. Gives off irritating or toxic fumes (or gases) in a fire.	Prevent dispersion of dust. Observe strict hygiene. Work with local exhaust. Wear protective gloves, clothing, and safety spectacles.	Reacts violently with oxidants and strong acids. Reacts with water at 50 °C forming flammable hydrogen and selenious acids. Reacts with incandescence on gentle heating with phosphorus and metals such as nickel, potassium, platinum, sodium and zinc.
Silver Ag	White metal, turns dark on exposure to ozone, hydrogen sulfide or sulfur; m.p. 962 °C b.p. 2212 °C.	Inhalation of high amounts of metallic silver vapours may cause lung damage with pulmonary oedema. May cause a grey-blue discoloration of the eyes, nose, throat and skin on long-term or repeated exposure (argyria).	Not combustible except as powder.	Work with local exhaust. Wear protective gloves and safety spectacles or eye protection in combination with respiratory protection for powder or fume.	Incompatible with acetylene, ammonium compounds, oxalic acid and tartaric acid.

CHEMICAL	PHYSICAL PROPERTIES	HEALTH HAZARDS	FIRE HAZARDS	SAFETY PRECAUTIONS	INCOMPATIBLE CHEMICALS	OTHER HAZARDS
Silver nitrate AgNO <sub>3</sub>	White crystals; m.p. 212 °C b.p. 444 °C; soluble in water.	May cause severe irritation and burns to eyes and skin. Corrosive by ingestion. May cause a red-blue discoloration of the skin on long-term or repeated exposure (argyria).	Not combustible but enhances combustion of other substances.	Prevent dispersion of dust. Observe strict hygiene. Wear protective rubber or plastic gloves, and face shield or eye protection in combination with respiratory protection. In case of contact with eyes, rinse with water and seek medical advice.	Ammoniacal solutions can precipitate explosive silver nitrite in the presence of base or glucose. Can form explosive products with ethanol and may cause explosive polymerization with acrylonitrile. May cause ignition of explosion if mixed with charcoal, magnesium, phosphorus or sulfur.	
Sodium azide N <sub>3</sub> Na	Colourless crystalline solid; m.p. 300 °C; soluble in water.	Very toxic by ingestion, inhalation and skin contact; may cause burns. Dust and solution irritate eyes and skin; may be absorbed through skin.	Decomposes explosively when heated above its melting point. Gives off toxic fumes when heated; do not use water to extinguish fires.	In case of contact with skin, wash immediately. Do not inhale dust. Wear rubber or plastic gloves and eye protection.	Explosive reactions with bromine, carbon disulfide or chromyl chloride. Solid reacts with heavy metals including copper, lead and mercury to form explosive metal azide salts. On contact with acid, develops highly toxic and explosive gas.	
Sodium biselenite NaHSeO <sub>3</sub>	Colourless, white crystalline powder; soluble in water.	Toxic by ingestion and inhalation of dust; possible danger of cumulative effects. Experimental teratogen. Prolonged skin contact may cause dermatitis.		Wear protective clothing.	Oxidizing agents.	

ANNEX 5. CHEMICALS: HAZARDS AND PRECAUTIONS

Sodium cyanide NaCN	Extremely toxic by ingestion, inhalation and skin contact; severely irritating to eyes. May be absorbed through skin. Repeated exposure may affect thyroid.	May give off toxic fumes in a fire.	Do not inhale dust; use respiratory protection. Avoid eye and skin contact; in case of contact with skin, wash immediately with water and remove contaminated clothing. Wear chemical-grade goggles and rubber or plastic gloves. Keep in a securely locked, ventilated store.	Liberates extremely toxic hydrogen cyanide (HCN) gas on contact with acids or with water containing dissolved carbon dioxide. Can form explosive mixtures with nitrites.	Treat spillage of solutions with bleaching powder (sodium hypochlorite) and leave for 24 h. Sweep up solid spills carefully and add to water containing bleaching powder; leave for 24 h before discarding. Keep cyanide antidote kit available in the laboratory.
Sodium hydroxide NaOH	Solid and concentrated dust causes damage to respiratory tract, lung oedema. Corrosive by ingestion. Dilute solutions irritating to eyes or may cause severe damage if eye contact is prolonged.	Not combustible. Contact with moisture or water may generate sufficient heat to ignite combustible substances.	In case of contact with eyes rinse immediately and seek medical advice; in case of contact with skin wash immediately with water, remove contaminated clothing. Wear rubber or plastic gloves and eye protection even with dilute solutions.	Evolves large quantity of heat when mixed with water. Reacts vigorously with chloroform-methanol mixtures and with strong acids.	Store in well-sealed container in dry place.

CHEMICAL	PHYSICAL PROPERTIES	HEALTH HAZARDS	FIRE HAZARDS	SAFETY PRECAUTIONS	INCOMPATIBLE CHEMICALS	OTHER HAZARDS
Sodium hypochlorite solution (10–14% available chlorine) NaOCl	Colourless or pale yellow solution with chlorine odour; miscible with water.	Corrosive to eyes and skin; corrosive by ingestion and to respiratory tract; inhalation may cause lung oedema. Repeated exposure may cause skin sensitization.	Strong oxidant. May give off toxic fumes in a fire.	In case of contact with eyes, rinse immediately with water and seek medical advice; in case of contact with skin, wash immediately. Do not inhale vapour; use respiratory protection. Work in well-ventilated area. Wear rubber or plastic gloves and chemical-grade eye protection.	Liberates highly toxic gas in contact with acids. Can react vigorously with combustible and reducing compounds. May react with nitrogen compounds to form explosive N-chloro-compounds; may react violently with methanol.	Gradually loses chlorine during storage; dilute solutions used as disinfectant rapidly deteriorate. Store away from acids in a dark, cool, well-ventilated area.
Sulfuric acid H <sub>2</sub> SO <sub>4</sub>	Colourless, odourless viscous liquid; m.p. 10 °C b.p. (decomposes) 340 °C.	Concentrated solution (15%) corrosive, causes severe burns; mist and vapour highly corrosive by inhalation; dilute solutions irritating to eyes and skin; cause burns and dermatitis.	May give off toxic fumes in a fire. Not combustible. Many reactions may cause fire or explosion. Dilution with water generates heat and spattering or boiling may occur. Always add acid to water, <b>never add water to acid.</b>	In case of contact with eyes rinse immediately and seek medical advice; in case of contact with skin wash immediately remove contaminated clothing. Wear nitrile gloves, eye and face protection. <b>No contact with flammable substances.</b>	Is a powerful oxidizing desiccant and reacts violently with many reagents including organic nitro compounds, potassium permanganate, alkali metals and perchlorates, combustible materials, oxidizers, amines, bases, water, excess heat and most metals.	Localized boiling may occur if concentrated acid is added to water.

<p>Tetrahydrofuran <math>C_4H_8O</math></p> <p>Diethylene oxide m.p. <math>-108.5\text{ }^{\circ}\text{C}</math></p> <p>Tetramethylene oxide b.p. <math>66\text{ }^{\circ}\text{C}</math>.</p>	<p>Central nervous system depressant causing narcosis. Eye, skin and respiratory irritation.</p>	<p>Highly flammable; may form explosive peroxides; flashpoint <math>-14\text{ }^{\circ}\text{C}</math>. Water may be ineffective to fight fires involving tetrahydrofuran, but it can be used to cool fire-exposed containers.</p>	<p>Work with ventilation, local exhaust or respiratory protection, protective gloves, safety spectacles.</p>	<p>Reacts violently with strong oxidants, strong bases and some metal halide, causing fire and explosion hazard. Attacks some forms of plastics, rubber and coatings. Tetrahydrofuran may polymerize in the presence of cationic initiators. Refluxing with calcium hydroxide can cause explosions.</p>
<p>Thallium acetate <math>Tl_2C_2H_3O_2</math></p> <p>White deliquescent crystals; m.p. <math>110\text{ }^{\circ}\text{C}</math>; very soluble in water.</p>	<p>Extremely toxic by ingestion with possible cumulative effects. Affects nervous and cardiovascular systems. Harmful through eye and skin contact.</p>			<p>Keep container tightly closed. Work in fume cupboard, hood or with exhaust ventilation. Wear protective clothing including dust respirator, chemical-grade goggles, rubber or plastic gloves, eye protection.</p>
<p><i>o</i>-Tolidine <math>(C_6H_5-(3CH_3)-(4NH_2))_2</math></p> <p>3,3'-Dimethyl-(1,1'-biphenyl)-4,4'-diamine</p>	<p>Harmful by contact with skin or ingestion. Dust irritates respiratory tract and eyes. Probably a human carcinogen.</p>	<p>Combustible. Gives off irritating or toxic fumes (or gases) in a fire.</p>	<p>Avoid contact; wear eye protection and gloves.</p>	<p>Oxidizing agents.</p>

CHEMICAL	PHYSICAL PROPERTIES	HEALTH HAZARDS	FIRE HAZARDS	SAFETY PRECAUTIONS	INCOMPATIBLE CHEMICALS	OTHER HAZARDS
Toluene C <sub>7</sub> H <sub>8</sub> Methylbenzene	Colourless liquid with characteristic odour; m.p. -95 °C; b.p. 111 °C; not miscible with water.	Central nervous system depressant. Irritation of eyes, mucous membranes, skin. Repeated exposure may cause toxicity in human reproduction or development.	Highly flammable; vapour may cause flash fire; flashpoint 4 °C flammable range 1.4–7%. Extinguishing media for a small fire: dry chemicals, carbon dioxide, foam, water fog or inert gas (nitrogen).	Keep container tightly closed; keep away from ignition sources; earth/ (ground) containers to prevent static electrical discharge. Do not inhale vapour; use respiratory protection. Work in fume cupboard or well-ventilated area. Wear nitrile gloves.	Can react with strong acids, alkalis and oxidizers.	
Trichloroacetic acid CCl <sub>3</sub> COOH	White hygroscopic crystals with pungent odour; m.p. 58 °C b.p. 197.5 °C; soluble in water, ethanol, diethyl/ether.	Corrosive; causes severe burns to eyes, skin, respiratory tract.	Not combustible. May give off toxic fumes in fire.	Avoid contact with eyes and skin; wear rubber or plastic gloves and chemical-grade goggles or face shield in combination with respiratory protection. In case of contact with eyes, rinse immediately and seek medical advice.	Violent reaction with copper/dimethyl sulfoxide mixtures and on contact with bases, strong oxidizing agents and metals such as iron, zinc, aluminium.	Store in a dry place. Concentrated aqueous solutions may decompose violently.



Trichloroethylene CHClCCl <sub>2</sub>	Colourless liquid, characteristic odour; m.p. -73 °C b.p. 87 °C.	Irritation of eyes, skin; prolonged exposure may cause dermatitis and affect the central nervous system resulting in loss of memory. May affect liver and kidneys. Probably a human carcinogen.	Combustible under specific conditions.	Work with ventilation, local exhaust. Wear gloves, safety spectacles or other eye protection in combination with respiratory protection.	On contact with hot surfaces or flames, decomposes forming toxic and corrosive gases (phosgene, hydrogen chloride). Decomposes on contact with strong alkali producing dichloroacetylene; reacts violently with metal powders such as aluminium, barium, magnesium and titanium; slowly decomposed by light in the presence of moisture, with formation of hydrochloric acid.
Xylene (mixed isomers) C <sub>8</sub> H <sub>10</sub> (CH <sub>3</sub> ) <sub>2</sub> Dimethylbenzene	Colourless liquid with aromatic odour; m.p. -95 to -13 °C b.p. 136-145 °C; insoluble in water.	May affect central nervous system resulting in headache, dizziness, fatigue and nausea. Liquid and vapour irritate eyes, skin, mucous membranes, respiratory tract. Harmful if ingested. Prolonged skin contact may defat the skin. Non-specific neurological impairment. Exposure may enhance hearing damage caused by exposure to noise. Animal tests suggest toxicity to human reproduction or development.	Flammable liquid; flashpoint 27-32 °C.	Avoid contact with eyes. Wear nitrile gloves and eye protection. Keep container tightly closed; keep away from ignition sources.	May contain ethylbenzene as an impurity. Ethylbenzene is a possible human carcinogen.

# Index

- abrasions 79
- access
  - animal facilities 29, 30, 31
  - laboratory 9–10, 21, 26
- accidents 11
  - equipment-related 144
  - see also* first aid; injuries; spills
- acetaldehyde 146
- acetic acid 146
- acetic anhydride 146
- acetone 147
- acetonitrile 147
- acetylene 147
- acrolein 148
- aerosols
  - activities generating 51
  - biological safety cabinets and 15, 51
  - pipetting hazards 63
  - release of potentially infectious 79
  - safety equipment and 61
- air, exhaust *see* exhaust air
- air filters *see* high-efficiency particulate air (HEPA) filters
- airflow, directional
  - alarms 21, 60
  - animal facilities 29, 30, 31
  - biological safety cabinets 53, 56
  - Biosafety Level 3: 21
  - Biosafety Level 4: 26–27
- air systems
  - biological safety cabinets 51–52, 53–54, 56–57
  - protective suit 26
  - see also* ventilation systems
- airlocks 26, 27, 31
- alarms 21, 60
- alcohol-based hand rubs 87–88, 90
- alcohols **87–88**
- allergy, latex 66
- 2-amino-ethanol 154
- ammonia solutions 148
- ammonium bicarbonate 89
- ampoules of infectious materials
  - opening **74**
  - storage **74**
- anaerobic jars/incubators 142, 144
- aniline 148
- animal facilities 10, **28–32**
  - Biosafety Level 1: 29
  - Biosafety Level 2: 29–30
  - Biosafety Level 3: 30–31
  - Biosafety Level 4: 31–32
  - containment levels 28
  - invertebrates 32
- animal facility Biosafety Levels (ABSL) 28
- animals
  - disposal of carcasses 30
  - non-experimental 10, 29
  - transgenic and knock-out **102–103**
- anterooms 21, 30, 31
- antimicrobial 82
- antiseptics 82, 87, 88
- aprons 64, 65
- arthropods
  - control of verminous 12, 29
  - housing facilities 32
- audit 36–37
- auramine 148
- autoclaves 63, **90–92**
  - animal facilities 30, 31
  - availability 13, 16, 22, 27
  - double-door pass-through 26, 27

- fuel-heated pressure cooker 91
- gravity displacement 90, 91
- loading 91
- pre-vacuum 91
- precautions for use 92
- validation 16
- autoclaving 18, **90–92**
- azides 108, 164
  
- backflow prevention 14, 22
- basic laboratory (Biosafety Levels 1 and 2) **1, 9–19**
  - chemical, fire, electrical, radiation and equipment safety 19
  - code of practice 9–12
  - design and facilities 12–14, 15
  - equipment 13–16
  - health and medical surveillance 16
  - safety survey forms 38–42
  - training 16–17
  - waste handling 17–19
- bedding, animal 30, 31
- bench tops 12
- benzene 149
- benzidine 149
- biocide 82
- biohazard warning sign 9, 10, 20, 29
- biological expression systems 102
- biological safety cabinets (BSCs) **51–60, 62**
  - air connections 56–57
  - animal facilities 30
  - certification 59
  - class I 51–53, 55
  - class II 52–54, 55
    - type A1 53–54
    - types A2, B1 and B2 54, 55
  - class III 55, 56
    - laboratory 25–27
  - decontamination 59, **89**
  - exhaust air *see* under exhaust air
  - location 22, 57
  - operation and maintenance 58
  - prion contamination 77
  - required use 15, 21, 22
  - safe use **57–60, 70–71**
  - selection 52, 57
- biosafety
  - management 12
  - versus* laboratory biosecurity 47
- Biosafety Collaborating Centres, WHO **140**
- biosafety committee **118**
- Biosafety Level 1: 1, 3, **9–19**
  - animal facilities 29
  - laboratory design 12–14
  - laboratory safety survey form 38–40
  - health and medical surveillance 16
  - see also* basic laboratory
- Biosafety Level 2: 1, 3, **9–19**
  - animal facilities 29–30
  - laboratory design 12–14, 15
  - laboratory safety survey form 41–42
  - health and medical surveillance 16
  - see also* basic laboratory
- Biosafety Level 3: 1, 3, **20–23**
  - animal facilities 30–31
  - laboratory design 21–22
  - laboratory safety survey form 43
  - see also* containment laboratory
- Biosafety Level 4: 1, 3, **25–27**
  - animal facilities 31–32
  - laboratory design 25–27
  - see also* maximum containment laboratory
- biosafety levels 1
  - animal facility (ABSL) 28
  - facility requirements 3
  - microbiological risk groups and 1–3
- biosafety officer 17, **117–118**
- biosecurity **47–48**
  - 1,1'-biphenyl-4,4'-diamine" 149
- bleach (sodium hypochlorite) **84–85, 89, 166**
- blenders 63–64, **73**
- blood, standard precautions **74–76**
- body fluids, standard precautions **74–76**
- boiling 90
- bottles, screw-capped 16, 63
- bromine 149
- BSCs *see* biological safety cabinets
- building maintenance services **119**
- Bunsen burners 70, 71

- cages
  - animal 30, 31
  - flying insects 32
- calcium hypochlorite 84
- carbon dioxide, solid (dry ice) 150
- carbon tetrachloride 150
- 4,4'-carbonyimidoylbis
  - (N,N-dimethylbenzamine) 148
- ceilings 12, 21
- centrifuges 72–73, 142
  - breakage of tubes in 79–80
  - containment accessories 22
  - improper use 144
- certification
  - biological safety cabinets 59
  - laboratory/facility 36–37
- checklist, safety 125–131
- chemical germicides 82, 83–88
- chemicals (hazardous) 19, 107–109
  - biological safety cabinets 57
  - explosive 108, 144
  - incompatible, general rules 107, 108
  - routes of exposure 107
  - safety checklist 130–131
  - specific 145–169
  - spills 108–109
  - storage 107
  - toxic effects 107–108
- children 10
- chilling facilities, arthropods 32
- chloramines 84, 85
- chlorine 84–85, 150
- chlorine dioxide 85–86, 151
- chlorine-releasing compounds 84–85
- chloroform 151
- chromic acid 151
- chromium VI oxide 151
- circuit-breakers 111
- class III cabinet laboratory 25–26
  - controlled air system 26–27
- clean-air work stations 51
- clean-up procedure, spills 95–97
- cleaning
  - biological safety cabinets 59
  - domestic 119
  - laboratory materials 83
  - refrigerators and freezers 73
- clothing, protective *see* personal protective equipment/clothing
- coats, laboratory 64, 65
- codes of practice
  - Biosafety Level 1 and 2: 9–12
  - Biosafety Level 3: 20–21
  - Biosafety Level 4: 25
- commissioning, laboratory/facility 33–35
- commissioning agent 33–34
- communication facilities 25
- contact lenses 11
- containers
  - broken 79
  - contaminated waste 18–19
  - leakproof 62
  - sharps disposal 18, 62
  - specimen 69, 75, 95
- containment, primary
  - at Biosafety Level 4 25–26
- containment laboratory (Biosafety Level 3)
  - 1, 3, 20–23
  - code of practice 20–21
  - design and facilities 21–22, 23
  - equipment 22
  - health and medical surveillance 22–23, 24
  - safety survey form 43
- containment levels, animal facility 28
  - see also* biosafety levels
- contaminated liquids/effluents 11, 27
- contaminated materials *see* infectious materials
- contingency plans 78
- copper 152
- cosmetics 11
- coveralls 64, 65
- Creutzfeldt-Jakob disease (CJD) 76
- culture stirrers, shakers, agitators 143
- cuts 79
- cyanogen bromide 152
- cytochalasin 152
- decontamination
  - biological safety cabinets 59, 89
  - blood/body fluids 76

- definition 82
- effluents 11, 27
- hand **90**
- local environmental **88–89**
- prion-contaminated materials 77
- waste materials 18, 22
  - see also* cleaning; disinfection
- desiccators 142
- design, laboratory
  - Biosafety Level 1 and 2: 12–14, 15
  - Biosafety Level 3: 21–22, 23
  - Biosafety Level 4: 25–27
  - commissioning requirements and 33
- diethyl ether 153
- diethylene dioxide 154
- diethylene oxide 167
- 3,3'-dimethyl-(1,1'-biphenyl)-4,4'-diamine 167
- dimethylamine 153
- dimethylbenzene 169
- 2,4-dinitrophenyl-hydrazine 153
- dioxane 154
- disasters, natural 78, 80
- disinfectants 82, **83–88**
- disinfection **82–93**
  - biological safety cabinets 59
  - chemical 83–88
  - cleaning prior to 82, 83
  - definition 82
  - heat 90–92
  - spills 95–97
  - waste materials 19
  - see also* decontamination; sterilization
- dispersal of infectious materials, avoiding 70
- doors
  - animal facilities 29
  - laboratory 13, 21, 26
- drains, containment 27
- drinking 11, 13, 30
- earth-fault-interrupters 111
- eating 11, 13, 30, 71
- effluents, contaminated 11, 27
- electrical hazards 19, **111**, 144
  - safety checklist **128**
- electricity supply 14, 27
- emergencies **78–81**
  - Biosafety level 4: 25, 27
  - contingency plans 78
  - laboratory procedures 79–81
- emergency equipment 81
- emergency services 80–81
- engineering services **119**
- equipment
  - basic laboratory **14–16**
  - containment laboratory **22**
  - emergency 81
  - hazards **141–144**
  - personal protective *see* personal protective equipment/clothing
  - safety 19, **61–66**
    - checklist **130**
- Escherichia coli* K12 102
- ethanol (ethyl alcohol) 87–88, 154
- ethanolamine 154
- ethers 108
- excreta, standard precautions **74–76**
- exhaust air
  - animal facilities 30
  - biological safety cabinets 22, 26, 51, 52–54, 56, 57
  - containment laboratory 21, 22
  - maximum containment laboratory 26–27
- explosive chemicals 108, 144
- expression systems, biological 102
- expression vectors 102
- eye protection 11, 64–65, 71
- face protection 11, 64–65
- face shields (visors) 11, 65
- facilities, laboratory
  - Biosafety Level 1 and 2: 12–14
  - Biosafety Level 3: 21–22, 23
  - Biosafety Level 4: 25–27
  - biosafety level designations 1
- films, for microscopy 75
- fire extinguishers 110–111
- fires 19, **110–111**
  - causes 110, 144
  - emergency procedures 80

- prevention and protection checklist 127
- first aid 13, **138**
- first-aid box 138
- flame photometer 144
- flames, open 59, 70
- flammable liquid storage **128**
- floors 12, 21
- food 11
- footwear 11, 20, 25, 65
- formaldehyde **86**, 89, 155
- formalin 86, 89
- freeze-dryers 143
- freezers **73–74**
- fumigation 89
- furniture, laboratory 12
- gas(es)
  - compressed and liquefied 109, **128**
  - supply to laboratory 14
- gene transfer 101, 102
- genetic engineering 101
- genetically modified organisms (GMOs) **101–104**
  - further considerations 104
  - risk assessments 103–104
  - types 102–103
- germicides, chemical 82, **83–88**
- glass 75
  - handling broken 79, 80, 95
  - precautions in use 71, 75
- gloves 10, 60, 65, **66**
- glutaraldehyde 86, 155
- GMOs *see* genetically modified organisms
- goggles 64–65
- good microbiological technique (GMT) 9–12, **69–77**
- gowns 64, 65
- hand decontamination **90**
- hand rubs, alcohol-based 87–88, 90
- hand washing 10, 66, **90**
  - animal facility staff 30
  - facilities 13, 21, 30
- health and medical surveillance
  - basic laboratory **16**
  - checklist **129**
  - containment laboratory **22–23**, 24
- hearing protection 111
- heat
  - disinfection and sterilization **90–92**
  - dry 90
  - moist 90
- heating, ventilation and air-conditioning (HVAC) system 21
  - safety checklist **126**
- HEPA filters *see* high-efficiency particulate air filters
- high-efficiency particulate air (HEPA) filters
  - animal facilities 30
  - biological safety cabinets 51, 53, 56
  - Biosafety Level 3: 21, 22
  - Biosafety Level 4: 26, 27
  - prion-contaminated 77
- homogenizers 63–64, **73**, 142
- horizontal and vertical outflow cabinets 51
- 1-hydrazino-2,4-dinitrobenzene 153
- hydrochloric acid 155
- hydrogen chloride 155
- peroxide **88**, 89, 156
- hydrogen sulfide 156
- illumination *see* lighting
- immunization, staff **139**
- incidents *see* accidents; spills
- incineration 19, **92–93**
- incinerators 31, 92
- infectious materials
  - autoclaving and reuse 18
  - avoiding dispersal **70**
  - contact with skin and eyes 71
  - decontamination *see* decontamination
  - disposal 18–19, 22
  - ingestion 71, 79
  - safety checklist **130**
  - spills 11, 79, **95–97**
- infective microorganisms, risk groups *see* risk groups, microbiological
- ingestion of infectious material 71, 79
- injuries
  - animal facility staff 30

- emergency procedures 79
- prevention 71–72
- inoculation, accidental 71–72
- insects, flying 32
- inspection, laboratory 36–37
- International Air Transport Association (IATA) 94
- International Civil Aviation Organization (ICAO) 94
- international transport regulations **94–95**
- invertebrates 32
- iodine **88**, 156
- iodophores **88**
- isolator cages 30, 31
- isolators, negative-pressure flexible-film **61**, 62
- isopropanol (isopropyl alcohol) 87, 162
  
- knock-out animals **102–103**
  
- labelling, specimen 74–75
- laboratory
  - biosafety levels *see* biosafety levels
  - biosecurity **47–48**
  - certification **36–37**
  - commissioning **33–35**
  - facilities *see* facilities, laboratory
  - premises, safety checklist **125**
  - safety survey forms 38–43
  - services, safety checklist **126–127**
  - techniques **69–77**
  - working areas 11
  - see also* basic laboratory; containment laboratory; maximum containment laboratory
- laboratory director 12, 117
- laboratory supervisors 12, 117
  - training role 17, 120
- latex allergy 66
- lighting 12, 14, **126**
- loops *see* transfer loops
- lyophilized infectious materials, opening ampoules **74**
- lyophilizers 143
  
- maintenance personnel 119
- maximum containment laboratory (Biosafety Level 4) 1, 3, **25–27**
  - code of practice 25
  - design and facilities 25–27
- medical contact card 22–23, 24
- medical surveillance *see* health and medical surveillance
- mercury 157
- methanol 157
- methylbenzene 168
- microbicide 82–83
- microbiological risk assessment *see* risk assessment, microbiological
- microincinerators 62, **64**
- microscopy, films and smears for 75
- mites 32
  
- naphthylamine 157
- natural disasters 78, 80
- needle-stick injuries, avoiding 71–72
- needles, hypodermic 11, 75, 141–142
  - disposal 18
- negative-pressure flexible-film isolators **61**, 62
- ninhydrin 158
- nitric acid 158
- nitrobenzene 158
- noise **111**
  
- osmium tetroxide 159
- outbreaks, diseases of unknown etiology 8
- oxalic acid 159
- oxygen 159
  
- packaging systems **95**, 96
- paraformaldehyde 86, 89
- peracids **88**
- perchloric acid 108, 160
- personal protective equipment/clothing **64–66**
  - animal facility 30, 31
  - basic laboratory 10–11
  - biological safety cabinet 60
  - checklist **129**
  - containment laboratory 20–21

- maximum containment laboratory 25, 26
- prions 77
- personnel
  - biosafety management 12
  - biosecurity issues 47
  - facilities, safety checklist **126**
  - health and medical surveillance *see* health and medical surveillance
  - immunization **139**
  - personal items/clothing 13
  - responsibility for own safety 117
  - support **119**
  - training *see* training
- phenol 160
- phenolic compounds **86–87**
- N*-phenyl- $\alpha$ -naphthylamine 157
- N*-phenyl- $\beta$ -naphthylamine 157
- phosphoric acid 161
- phosphorus pentoxide 161
- picric acid/picrates 108, 161
- pipettes 16, 70
- pipetting **70**
  - aids 15, 62, 63, 70
  - mouth 11, 63
- plants, transgenic 101, **103**
- plasmid pUC18 102
- poliovirus-susceptible mice 102–103
- potassium hydroxide 162
- potassium permanganate 162
- potassium tellurite 162
- precleaning 82, 83
- primary containment 25–26
- primates, non-human 29
- prions 76–77
- product protection 51, 53
- propan-2-ol (2-propanol) 87, 162
- protective suit 26
  - see also* suit laboratory
- pyridine 163
- quaternary ammonium compounds **87**
- radiation, ionizing 19, **111–114**
  - harmful effects 111
  - principles of protection 112–113
  - safety checklist **130–131**
  - work-bench area 113–114
- radiation area 113
- radiation hazard symbol 113, 114
- radioactive waste 114
- radionuclides
  - biological safety cabinets 57
  - safe working practices **112–113**
  - substitution 113
- recombinant DNA technology **101–104**
- refrigerators **73–74**, 144
- respirators (respiratory protective equipment) 21, **65–66**
- rest facilities 13
- risk assessment, microbiological 2, 7–8
  - animal facilities 28–29
  - genetically modified organisms **103–104**
- risk groups, microbiological
  - basic laboratories 9
  - biosafety levels and 2–3
  - classification 1–2
- rodent control 12, 29
- safety checklist **125–131**
- safety equipment *see* equipment, safety
- sanitation facilities 126
- screens, arthropod-proof 32
- screw-capped bottles 16, 63
- security precautions 14, 127
- selenium 163
- serum, separation 72
- shakers 63–64, **73**
- sharps **18**
  - animal facilities 30
  - avoiding injuries 66, 71–72, 75
  - disposal containers 18, 62
- shoes *see* footwear
- showers 26, 30
- silver 163
- silver nitrate 164
- skin
  - contact 71
  - puncture wounds, cuts and abrasions 79
  - see also* injuries



- smears, for microscopy 75
- smoking 11, 30
- soda ash (sodium carbonate) 109
- sodium azide 164
- sodium bicarbonate 109
- sodium biselenite 164
- sodium cyanide 165
- sodium dichloroisocyanurate (NaDCC)
  - 84, **85**
- sodium hydroxide 165
- sodium hypochlorite (bleach) **84–85**, 89, 166
- sonicators 63–64, **73**, 75, 142
- spatter shield 62
- specimens **69**
  - collection 74–75
  - containers 69, 75, 95
  - labelling 74–75
  - with limited information 8
  - opening packages 69
  - opening tubes and sampling contents 75
  - receipt 69
  - standard precautions 74–75
  - transport 69, 74–75
  - triple packaging system **95**, 96
- spectacles, safety 64–65
- spills
  - in biological safety cabinets 59
  - blood 76
  - chemical **108–109**
  - infectious materials 11, 79, **95–97**
- sporocide 83
- staff *see* personnel
- standard precautions **74–76**
- sterilization 27, **82–93**
  - cleaning prior to 82, 83
  - definition 83
  - heat **90–92**
  - prion-contaminated materials 77
  - see also* decontamination; disinfection
- storage
  - ampoules of infectious materials **74**
  - chemicals 108
  - compressed and liquefied gases 109, **128**
  - facilities, checklist **125**
  - flammable liquids **128**
  - space, laboratory 12
- suit, protective 26
- suit laboratory 26
  - controlled air system 26–27
- sulfuric acid 166
- support staff **119**
- survey, laboratory safety 36–37
  - forms 38–43
- syringes 11, 18
- tetrahydrofuran 167
- tetramethylene oxide 167
- thallium acetate 167
- ticks 32
- tissue grinders **73**, 142
- tissues
  - prion-containing 77
  - standard precautions 75
- o*-tolidine 167
- toluene 168
- total exhaust cabinet 57
- training **120–121**
  - animal facility workers 30, 31
  - biological safety cabinet use 60
  - biosecurity 47
  - laboratory workers **16–17**
- transfer loops
  - disposable 15, 62, **64**
  - microincinerators 62, **64**
  - safe use 70
- transgenic animals **102–103**
- transgenic plants 101, **103**
- transmissible spongiform encephalopathies (TSEs) 76
- transport 11, **94–97**
  - infectious waste 18–19, 22
  - international regulations 94–95
  - specimens 69, 74–75
  - triple packaging system 95, 96
- trichloroacetic acid 168
- trichloroethylene 169
- triclosan 87
- 2,4,6-trinitrophenol (picric acid) 108, 161
- triple packaging systems **95**, 96

- tubes
  - breakage in centrifuges 79–80
  - screw-capped 16
- two-person rule 25, 31
- ultra-centrifuges 142
- ultrasonic cleaners 142
- ultraviolet lights 58
- United Nations Committee of Experts on the Transport of Dangerous Goods (UNCETDG) 94
- universal precautions 74–76
- vacuum flasks 144
- vacuum lines 22, 63
- validation, equipment 16
- vectors 102
- ventilation systems
  - animal facilities 29, 30, 31
  - basic laboratory 14
  - checklist **126**
  - containment laboratory 21
  - maximum containment laboratory 26–27
- viral vectors 102
- walls 12, 21
- warranty periods, laboratory/facility 33
- waste **17–19**
  - animal facilities 30, 31
  - Biosafety Level 4: 27
  - decontamination 18, 22
  - disposal 18–19, 22, 93
  - invertebrate facilities 32
  - prion-contaminated 77
  - radioactive 114
- water baths 143
- water supply 14, 22
- windows
  - animal facilities 29, 31
  - invertebrate facilities 32
  - laboratory 11, 14, 21
- women of childbearing age 16, 129
- work surfaces
  - animal facilities 29
  - laboratory 11, 12
- working areas, laboratory 11
- World Health Organization (WHO)
  - Biosafety Collaborating Centres **140**
  - Biosafety programme 25
- xylene 169